

REAR BLADES

OPERATOR'S MANUAL

NVHA

Modelos

NVHA-180

NVHA-210

NVHA-240



No. de Parte
4350-2109-00

INTRODUCTION

TO THE DEALER:

Assembly and proper installation of this product is the responsibility of the BISON dealer. Read manual instructions and safety rules. Make sure all items on the Dealer's Pre-delivery and Delivery Check Lists in the Operator's Manual are completed before releasing equipment to the owner.

The dealer must complete the Warranty Registration, located on the BISON website. **Warranty claims will be denied if the Warranty Registration has not been completed.**

TO THE OWNER:

Read this manual before operating your BISON equipment. The information presented will prepare you to do a better and safer job. Keep this manual handy for ready reference. Require all operators to read this manual carefully and become acquainted with all the adjustment and operating procedures before attempting to operate. Replacement manuals can be obtained from your selling dealer.

The equipment you have purchased has been carefully engineered and manufactured to provide dependable and satisfactory use. Like all mechanical products, it will require cleaning and upkeep. Lubricate the unit as specified.

Observe all safety information in this manual and safety decals on the equipment.

For service, your authorized BISON dealer has trained mechanics, genuine BISON service parts, and the necessary tools and equipment to handle all your needs.

Use only genuine BISON service parts. Substitute parts will void the warranty and may not meet standards required for safe and satisfactory operation. Record the model number and serial number of your equipment in the spaces provided:

Model: _____ Date of Purchase: _____

Serial Number: (see Safety & Instructional Decals section for location) _____

Provide this information to your dealer to obtain correct repair parts.

Throughout this manual, the term **IMPORTANT** is used to indicate that failure to observe can cause damage to equipment. The terms **CAUTION**, **WARNING**, and **DANGER** are used in conjunction with the Safety-alert Symbol, (a triangle with an exclamation mark), to indicate the degree of hazard for items of personal safety.



This Safety-alert Symbol indicates a hazard and means **ATTENTION! BECOME ALERT! YOUR SAFETY IS INVOLVED!**



DANGER

Indicates an imminently hazardous situation that, if not avoided, will result in death or serious injury.



WARNING

Indicates a potentially hazardous situation that, if not avoided, could result in death or serious injury, and includes hazards that are exposed when guards are removed.



CAUTION

Indicates a potentially hazardous situation that, if not avoided, may result in minor or moderate injury.

IMPORTANT

Indicates that failure to observe can cause damage to equipment.

NOTE

Indicates helpful information.



TABLE OF CONTENTS

INTRODUCTION	ii
GENERAL INFORMATION	1
SPECIFICATIONS	2
SAFETY RULES	3
SAFETY & INSTRUCTIONAL DECALS	5
OPERATION	7
OWNER SERVICE	13
ASSEMBLY	15
PARTS INDEX	24
BOLT TORQUE CHART	29
BOLT SIZE CHART & ABBREVIATIONS	30
WARRANTY	31

GENERAL INFORMATION

The purpose of this manual is to assist you in operating and maintaining your rear blade. Read it carefully. It furnishes information and instructions that will help you achieve years of dependable performance. These instructions have been compiled from extensive field experience and engineering data. Some information may be general in nature, due to unknown and varying operating conditions. However, through experience and these instructions, you should be able to develop procedures suitable to your particular situation.

The illustrations and data used in this manual were current at the time of printing. However, due to possible inline production changes, your machine may vary slightly in detail. We reserve the right to redesign and change the machines as may be necessary without notification.

Throughout this manual, references are made to right and left direction. These are determined by standing behind the tractor facing the direction of forward travel.

NVHA-180 / NVHA-210 / NVHA-240 SPECIFICATIONS

Models	NVHA-180	NVHA-210	NVHA-240
Features & Specifications			
Angle, tilt, & offset	Manual or hydraulically adjusted angle and manually tilt and offset	Manual or hydraulically adjusted angle and manually tilt and offset	Manual or hydraulically adjusted angle and manually tilt and offset
Hitch compatibility	Cat. 1 iMatch Compatible	Cat. 1 iMatch Compatible	Cat. 1 iMatch Compatible
Frame	Formed steel double channel frame	Formed steel double channel frame	Formed steel double channel frame
Cutting edge	½" x 6" reversible	½" x 6" reversible	½" x 6" reversible
Angle/Pivot	360 Degrees	360 Degrees	360 Degrees
Angle-Forward	7, up to 45 degrees each side (manual) up to 40 degrees each side (hydraulic)	7, up to 45 degrees each side (manual) up to 40 degrees each side (hydraulic)	7, up to 45 degrees each side (manual) up to 40 degrees each side (hydraulic)
Angle-Reverse	7, up to 45 degrees each side	7, up to 45 degrees each side	7, up to 45 degrees each side
Moldboard thickness	1/4"	1/4"	1/4"
Moldboard length	72"	84"	96"
Moldboard height	15"	15"	15"
Moldboard type	3 bends	3 bends	3 bends
Moldboard upper edge	Full bend	Full bend	Full bend
Offset (or swing)	6" or 12" left or right	6" or 12" left or right	6" or 12" left or right
Tilt	0 to 20 degrees up and down	0 to 20 degrees up and down	0 to 20 degrees up and down
Operating weight	341 lbs.	366 lbs.	391 lbs.

*Tecnomec Agrícola, S.A. de C.V. reserves the right to make any changes deemed necessary to the specifications without prior notice.

SAFETY & INSTRUCTIONAL DECALS

ATTENTION! BECOME ALERT! YOUR SAFETY IS INVOLVED!

Safety is a primary concern in the design and manufacture of our products. Unfortunately, our efforts to provide safe equipment can be wiped out by an operator's single careless act.

In addition to the design and configuration of equipment, hazard control and accident prevention are dependent upon the awareness, concern, judgement, and proper training of personnel involved in the operation, transport, maintenance, and storage of equipment.

It has been said "The best safety device is an informed, careful operator." We ask you to be that kind of operator.

TRAINING

- Safety instructions are important! Read all attachment and power unit manuals; follow all safety rules and safety decal information. (Replacement manuals are available from your dealer). Failure to follow instructions or safety rules can result in serious injury or death.
- If you do not understand any part of this manual and need assistance, see your dealer.
- Know your controls and how to stop engine and attachment quickly in an emergency.
- Operators must be instructed in and be capable of the safe operation of the equipment, its attachments, and all controls. Do not allow anyone to operate this equipment without proper instructions.
- Never allow children or untrained persons to operate equipment.

PREPARATION

- Check that all hardware is properly installed. Always tighten to torque chart specifications unless instructed otherwise in this manual.
- Always wear relatively tight and belted clothing to avoid entanglement in moving parts. Wear sturdy, rough-soled work shoes and protective equipment for eyes, hair, hands, hearing, and head.
- Make sure attachment is properly secured, adjusted, and in good operating condition.
- Power unit must be equipped with ROPS or ROPS cab and seat belt. Keep seat belt securely fastened. Falling off power unit can result in death from being run over or crushed. Keep foldable ROPS systems in "locked up" position at all times.
- Make sure all safety decals are installed. Replace if damaged. (See Safety & Instructional Decals section for location).
- A minimum 20% of tractor and equipment weight must be on the tractor front wheels when attachments are in transport position. Without this weight, tractor could tip over, causing personal injury or death. The weight may be attained with a loader, front wheel weights, ballast in tires or front tractor weights. Weigh the tractor and equipment. Do not estimate.

OPERATION

- Do not allow bystanders in the area when operating, attaching, removing, assembling, or servicing equipment.
- Do not operate equipment while under the influence of alcohol or drugs.
- Operate only in daylight or good artificial light.
- Keep hands, feet, hair, and clothing away from equipment while engine is running. Stay clear of all moving parts.

(Safety Rules continued on next page)

SAFETY & INSTRUCTIONAL DECALS

ATTENTION! BECOME ALERT! YOUR SAFETY IS INVOLVED!

(Safety Rules continued from previous page)

- Always comply with all state and local lighting and marking requirements.

- Never allow riders on power unit or attachment.

- Power unit must be equipped with ROPS or ROPS cab and seat belt. Keep seat belt securely fastened. Falling off power unit can result in death from being run over or crushed. Keep foldable ROPS systems in "locked up" position at all times.

- Always sit in power unit seat when operating controls or starting engine. Securely fasten seat belt, place transmission in neutral, engage brake, and ensure all other controls are disengaged before starting power unit engine.

- Look down and to the rear and make sure area is clear before operating in reverse.

- Do not operate on steep slopes.

- Do not stop, start, or change directions suddenly on slopes.

- Use extreme care and reduce ground speed on slopes and rough terrain.

- Watch for hidden hazards on the terrain during operation.

- Stop power unit and equipment immediately upon striking an obstruction. Turn off engine, remove key, inspect, and repair any damage before resuming operation.

- Before changing positions of manual swing, tilt, or angle positions:

- Park tractor on level ground, apply parking brake, level implement boom, shut off tractor, and remove key.

- Make manual changes slowly and carefully to prevent hazardous movement of mechanisms.

- Never stand in positions where you could become entrapped during adjustment changes or if the 3-point hitch suddenly lowers.

- Always secure lock pins with safety pins to prevent lock pins from bumping out of the positioning holes. Failure to do so may result in accidents and/or damage to rear blade.

- Before dismantling power unit or performing any service or maintenance, follow these steps: disengage power to equipment, lower the 3-point hitch and all raised components to the ground, operate valve levers to release any hydraulic pressure, set parking brake, stop engine, remove key, and unfasten seat belt.

- Before working underneath, read manual instructions, securely block up, and check stability. Secure blocking prevents equipment from dropping due to hydraulic leak down, hydraulic system failure, or mechanical component failure.

MAINTENANCE

- Before dismantling power unit or performing any service or maintenance, follow these steps: disengage power to equipment, lower the 3-point hitch and all raised components to the ground, operate valve levers to release any hydraulic pressure, set parking brake, stop engine, remove key, and unfasten seat belt.

- Before performing any service or maintenance, lower attachment to ground, turn off engine, set parking brake, and remove key.

- Before working underneath, read manual instructions, securely block up, and check stability. Secure blocking prevents equipment from dropping due to hydraulic leak down, hydraulic system failure, or mechanical component failure.

- Always wear relatively tight and belted clothing to avoid entanglement in moving parts. Wear sturdy, rough-soled work shoes and protective equipment for eyes, hair, hands, hearing, and head.

- Do not modify or alter or permit anyone else to modify or alter the equipment or any of its components in any way.

- Make sure attachment is properly secured, adjusted, and in good operating condition.

- Never perform service or maintenance with engine running.

- Keep all persons away from operator control area while performing adjustments, service, or maintenance.

- Tighten all bolts, nuts and screws to torque chart specifications. Check that all cotter pins are installed securely to ensure equipment is in a safe condition before putting unit into service.

- Make sure all safety decals are installed. Replace if damaged. (See Safety & Instructional Decals section for location).

STORAGE

- Secure equipment parking stand(s) in park position before detaching.

- Keep children and bystanders away from storage area.

SAFETY & INSTRUCTIONAL DECALS
ATTENTION! BECOME ALERT! YOUR SAFETY IS INVOLVED!

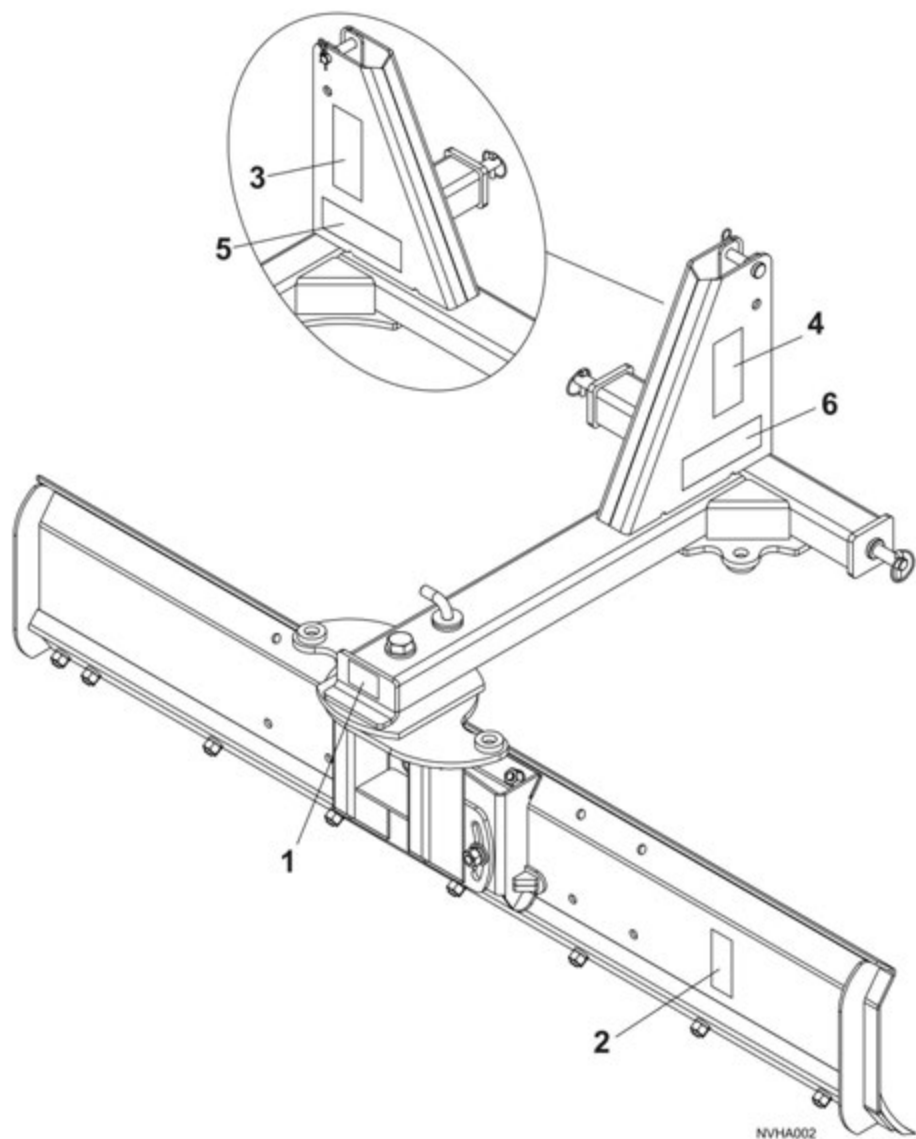



1 - Serial Number Plate (1)



SAFETY & INSTRUCTIONAL DECALS

ATTENTION! BECOME ALERT! YOUR SAFETY IS INVOLVED!

2.- TA4310-7071-00 (1)*

 WARNING

CRUSHING AND PINCHING HAZARD
<ul style="list-style-type: none">■ Be extremely careful handling various parts of the hitching mechanism. They are heavy and hands, fingers, feet, and other body parts could be crushed or pinched between tractor and implement.■ Operate tractor controls from tractor seat only.■ Do not stand between tractor and implement when tractor is in gear.■ Make sure parking brake is engaged before going between tractor and implement.■ Stand clear of machine while in operation or when it is being raised or lowered.
FAILURE TO FOLLOW THESE INSTRUCTIONS COULD RESULT IN SERIOUS INJURY OR DEATH. <small>1002941</small>

3.- TA4310-7072-00 (1)*

 WARNING
TO AVOID SERIOUS INJURY OR DEATH:
<ul style="list-style-type: none">■ Read Operator's Manual before operating, servicing, or repairing equipment. Follow all safety rules and instructions. (Manuals are available from your selling dealer.)■ Never allow riders.■ Keep bystanders away from equipment during operation.■ Operate from tractor seat only.■ Keep all shields in place and in good condition.■ Lower equipment to ground, stop engine, remove key, and set brake before dismounting tractor.■ Never allow children or untrained persons to operate equipment.
FAILURE TO FOLLOW THESE INSTRUCTIONS CAN RESULT IN INJURY OR DEATH. <small>1003199</small>

4.- TA4310-7073-00 (1)*

 WARNING

FALLING OFF CAN RESULT IN BEING RUN OVER
<ul style="list-style-type: none">■ Tractor must be equipped with ROPS (or ROPS CAB) and seat belt. Keep foldable ROPS systems in "locked up" position at all times.■ Buckle Up! Keep seat belt securely fastened.■ Allow no riders.
RAISED IMPLEMENT CAN DROP AND CRUSH.
<ul style="list-style-type: none">■ Never go underneath raised implement which can drop from equipment or tractor 3-point hitch hydraulic leak down, hydraulic system failures, movement of control levers, or mechanical linkage failures.■ Service work does not require going underneath implement. Read manual instructions.
FALLING OFF OR GOING UNDERNEATH IMPLEMENT CAN RESULT IN SERIOUS INJURY OR DEATH. <small>55121-C</small>

5.- TA4310-1102-03 BISON decal (2)

6.- Model decal (1)

*Included in Safety Decal Kit TACN07110015K

BE CAREFUL!

Use a clean, damp cloth to clean safety decals.

Avoid spraying too close to decals when using a pressure washer; high-pressure water can enter through very small scratches or under edges of decals causing them to peel or come off.

Replacement safety decals can be ordered free from your dealer.

OPERATION

Safety is a primary concern in the design and manufacture of our products. Unfortunately, our efforts to provide safe equipment can be wiped out by an operator's single careless act.

In addition to the design and configuration of equipment, hazard control and accident prevention are dependent upon the awareness, concern, judgement, and proper training of personnel involved in the operation, transport, maintenance, and storage of equipment.

It has been said "The best safety device is an informed, careful operator." We ask you to be that kind of operator.

WARNING

- Never allow children or untrained persons to operate equipment.
- Do not allow bystanders in the area when operating, attaching, removing, assembling, or servicing equipment.
- Before working underneath, read manual instructions, securely block up, and check stability. Secure blocking prevents equipment from dropping due to hydraulic leak down, hydraulic system failure, or mechanical component failure.
- Never allow riders on power unit or attachment.
- Keep all persons away from operator control area while performing adjustments, service, or maintenance.

WARNING

- A minimum 20% of tractor and equipment weight must be on the tractor front wheels when attachments are in transport position. Without this weight, tractor could tip over, causing personal injury or death. The weight may be attained with a loader, front wheel weights, ballast in tires, or front tractor weights. Weigh the tractor and equipment. Do not estimate.

CAUTION

- Always wear relatively tight and belted clothing to avoid entanglement in moving parts. Wear sturdy, rough-soled work shoes and protective equipment for eyes, hair, hands, hearing, and head.

MOUNT REAR BLADE TO TRACTOR

▲ IMPORTANT

The rear blade should be mounted on tractors with a maximum power rating of 65 hp (48 kW). For 4WD tractors, the maximum power rating is 60 hp (45 kW).

The rear blade is a 3-point Category 1 implement. It will attach to ASAE standard Category 1 quick-attaching coupler.

Place the tractor rockshift control in "position control" (non-floating) for attaching and detaching the rear mounted blade. "Draft control" or "position control" can be used while operating.

Back the tractor until the ends of the lift arms can be attached to the lift points on the implement. Secure the lift arms to the mast.

Attach the center link to the top of the mast and adjust so that the rear blade will be level in the operating position.

CATEGORY 1

1. Place the lift arms around the lower hitch pins (8). Secure with klik pin (22).
2. Connect the tractor top link to upper hitch support hole of the 3-point hitch mast (1) using the upper hitch pin category 1 (6). Secure with the 1/8 safety pin (21).
3. Level the main frame by adjusting lift and top links.
4. Position sway blocks to eliminate side sway or install sway braces if required.

CATEGORY 1 QUICK-HITCH

1. Insert 1 7/16 O.D. lower hitch pin bushings* around the lower hitch pins (8). Secure with klik pins (22).
2. Place upper hitch pin category 1 (6) and 1 1/4 O.D. upper hitch pin bushing* category 1 in the lower hitch support hole of the 3-point hitch mast (1) and secure with the 1/8 safety pin (21).
3. Back up tractor with 3 quick-hitch attachment into 3-point hitch mast (1) making sure pins are aligned to the center and the outside lower hitch supports.
4. Lift tractor lift arms.
5. Level the main frame by adjusting lift and top links.
6. Position sway blocks to eliminate side sway or install sway braces if required.

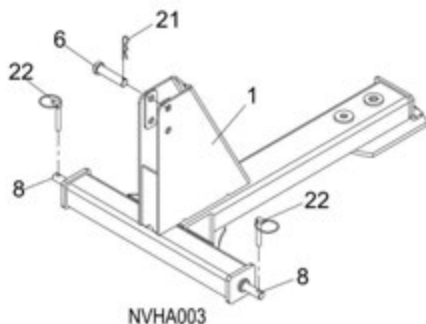

Figure 1. 3-point Hitch Connection

***NOTE:** The upper and lower hitch pin bushings are not included with rear blade.

NOTE: The drawbar may have to be removed on some tractors. Make sure rear blade is at least six inches from tractor tires, throughout operating range of 3-point hitch.

Operation Cont'd

CAUTION

- Before changing positions of manual swing, tilt, or angle positions:
 - Park tractor on level ground, apply parking brake, level implement boom, shut off tractor, and remove key.
 - Make manual changes slowly and carefully to prevent hazardous movement of mechanisms.
 - Never stand in positions where you could become entrapped during adjustment changes or if the 3-point hitch suddenly lowers.

CAUTION

- Always secure lock pins with safety pins to prevent lock pins from bumping out of the positioning holes. Failure to do so may result in accidents and/or damage to rear blade.

Angle Adjustment

Mechanical Adjustment

Insert the turn table pin (5) using the various hole combinations between the offset plate assembly and the turn table holes to achieve angle positions up to 45 degrees each side. Secure turn table pin (5) with safety pin (21).

Adjustment with Hydraulic Angle Cylinder

The blade may be angled from 0 to 40 degrees to the right or left by hydraulic remote control from the tractor seat.

1. Raise the blade a few inches off the ground by operating the lift control lever of the tractor.
2. Actuate the control valve connected to the angle cylinder.
3. On tractors with two circuit selector valves, select angling circuit and actuate the tractor control valve connected to selector valve.

NOTE: Do not operate the selector valve under load.

NOTE: Do not use the angle cylinder at the same time the angle pin is installed, since doing so will damage the cylinder and the rear blade.

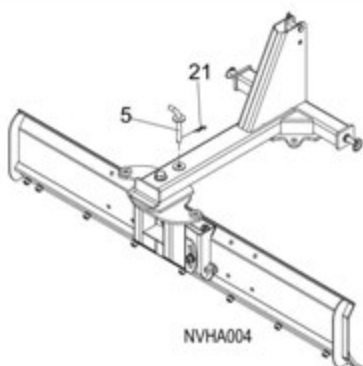

Figure 2. Turn Table Pin

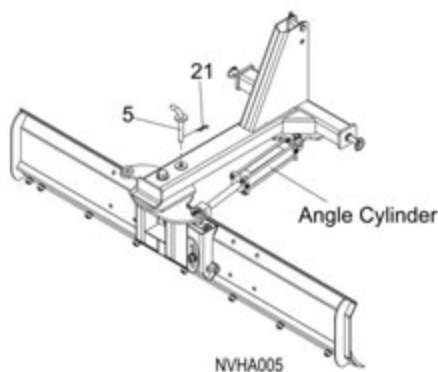

Figure 3. Hydraulic Angle Cylinder

Operation Cont'd

Reverse Blade

The blade is reversible without removing it from the tractor.

Mechanical Adjustment

1. Remove turn table pin (5) and safety pin (21).
2. Rotate moldboard counter-clockwise 180 degrees (viewed from the top).
3. Insert the turn table pin (5) using the various hole combinations between the offset plate assembly and the turn table holes to achieve angle positions up to 45 degrees each side. Secure turn table pin (5) and safety pin (21).

Adjustment with Hydraulic Angle Cylinder

1. Remove the clevis pin retainer and the clevis pins from the angle cylinder.
2. Raise blade off the ground using tractor's 3-point hitch.
3. Rotate moldboard counter-clockwise 180 degrees (viewed from the top).
4. Replace the cylinder, the cylinder clevis pin, and the clevis pin retainer.

NOTE: The blade can be set hydraulically to any angle from 0 to 40 degrees, right or left.

NOTE: Do not use the angle cylinder at the same time the turn table pin (5) is installed, since doing so will damage the angle cylinder and the blade.

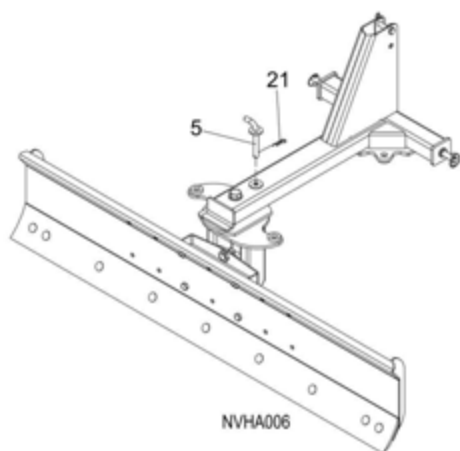

Figure 4. Reverse Blade

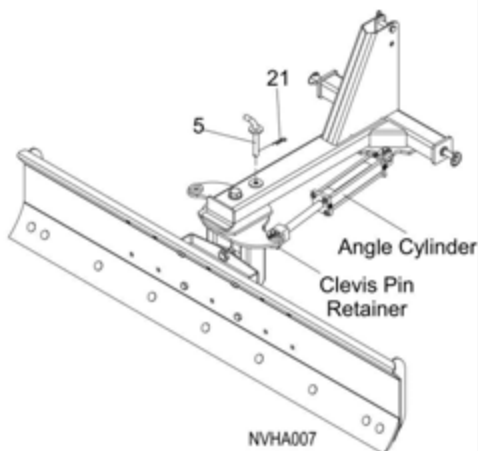

Figure 5. Adjustment Hydraulic Angle Cylinder

Tilt Adjustment

Mechanical Adjustment

Loose turn table washer (7), hex nut (14) and lock washer (19) to achieve angle tilt positions up to 20 degrees up and down.

NOTE: In some cases it may not be possible to fully tilt and angle and still be able to raise the blade high enough to clear the ground. In this case, use less tilt.

NOTE: It is possible for the blade to contact other components if the blade is tilted when angled. Operate blade slowly when angling it.

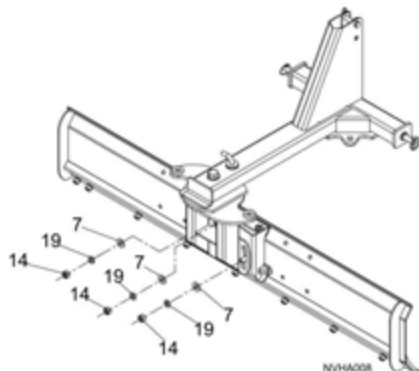

Figure 6. Upper Turn Table Pin

Offset Adjustment

Mechanical Adjustment

Mechanical adjustment model has five blade offset positions. Hole position combinations between the backing (3) and the moldboard (4) allow moldboard to offset to the right or left with a maximum blade offset of 12 inches to either side.

To offset the blade:

1. Park the tractor on level ground.
2. Apply parking brake.
3. Shut off the engine.
4. Disassemble the moldboard (4) from the backing (3) by removing the four bolts (9), four hex nuts (13), and the four lock washers (18).
5. Place the moldboard (4) to the desired position, right or left. Make sure the holes between backing (3) and moldboard (4) are aligned.
6. Secure moldboard with the four bolts (9), four hex nuts (13) and the four lock washers (18).

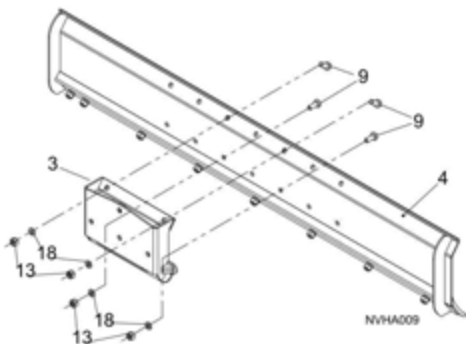

Figure 7. Mechanical Offset

Operation Cont'd

OPERATING TIPS

WARNING

- Look down and to the rear and make sure area is clear before operating in reverse.
- Do not operate on steep slopes.
- Do not operate while the parking stand is in the down position.
- Do not stop, start, or change directions suddenly on slopes.
- Use extreme care and reduce ground speed on slopes and rough terrain.
- Watch for hidden hazards on the terrain during operation.
- Before working underneath, read manual instructions, securely block up, and check stability. Secure blocking prevents equipment from dropping due to hydraulic leak down, hydraulic system failure, or mechanical component failure.

CAUTION

- Stop power unit and equipment immediately upon striking an obstruction. Turn off engine, remove key, inspect, and repair any damage before resuming operation.

BACKFILLING

For backfilling ditches or trenches, reverse the blade by rotating counter-clockwise and back push.

LEVELING AND GRADING

Set the blade to the desired position of offset, angle, and tilt for leveling and grading.

PRE-OPERATION CHECK LIST (OPERATOR'S RESPONSIBILITY)

- ___ Review and follow all safety rules and safety decal instructions on pages 3 through 6.
- ___ Check that equipment is properly and securely attached to tractor.
- ___ Check that all safety decals are installed and in good condition. Replace if damaged.
- ___ Check that all hardware and cotter pins are properly installed and secured.

PRE-OPERATION CHECK LIST (OPERATOR'S RESPONSIBILITY)

- ___ Check all lubrication points are greased.
- ___ Check that blade cutting edge is in good condition.

OWNER SERVICE

Safety is a primary concern in the design and manufacture of our products. Unfortunately, our efforts to provide safe equipment can be wiped out by an operator's single careless act.

In addition to the design and configuration of equipment, hazard control and accident prevention are dependent upon the awareness, concern, judgement, and proper training of personnel involved in the operation, transport, maintenance, and storage of equipment.

It has been said "The best safety device is an informed, careful operator." We ask you to be that kind of operator.

WARNING

- Before working underneath, read manual instructions, securely block up, and check stability. Secure blocking prevents equipment from dropping due to hydraulic leak down, hydraulic system failure, or mechanical component failure.
- Never perform service or maintenance with engine running.

WARNING

- Before dismounting power unit or performing any service or maintenance, follow these steps: disengage power to equipment, lower the 3-point hitch and all raised components to the ground, operate valve levers to release any hydraulic pressure, set parking brake, stop engine, remove key, and unfasten seat belt.
- Keep all persons away from operator control area while performing adjustments, service, or maintenance.

CAUTION

- Always wear relatively tight and belted clothing to avoid entanglement in moving parts. Wear sturdy, rough-soled work shoes and protective equipment for eyes, hair, hands, hearing, and head.

Owner Service *Cont'd*

Blade Cutting Edge

To reverse the cutting edge

1. Remove the 5/8 plow bolts.
2. Remove the cutting edge from the moldboard and reinstall with the sharp edge down.
3. Replace cutting edge when both edges are worn.

Lubrication

Monthly

1. Lubricate between turn table (2) and offset plate assembly (1).

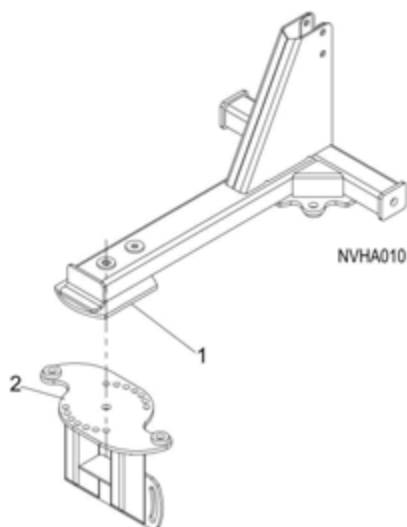

Figure 8. Lubrication Points

Bolts

1. Check bolts periodically to be sure they are tight.
2. Replace bolts as needed.

NOTE: Replacement bolts must have the same strength markings on the heads. Refer to Bolt Torque Chart on page 29.

ASSEMBLY

WARNING

- Before dismounting power unit or performing any service or maintenance, follow these steps: disengage power to equipment, lower the 3-point hitch and all raised components to the ground, operate valve levers to release any hydraulic pressure, set parking brake, stop engine, remove key, and unfasten seat belt.
- Before working underneath, read manual instructions, securely block up, and check stability. Secure blocking prevents equipment from dropping due to hydraulic leak down, hydraulic system failure, or mechanical component failure.
- Keep all persons away from operator control area while performing adjustments, service, or maintenance.

CAUTION

- Always wear relatively tight and belted clothing to avoid entanglement in moving parts. Wear sturdy, rough-soled work shoes and protective equipment for eyes, hair, hands, hearing, and head.
- Tighten all bolts, nuts and screws to torque chart specifications. Check that all safety and cotter pins are installed securely to ensure equipment is in a safe condition before putting unit into service.

Dealer Set-Up Instructions

Assembly of this equipment is the responsibility of the BISON dealer. It should be delivered to the owner completely assembled, lubricated, and adjusted for normal operating conditions. Assembly will be easier if components are aligned and loosely assembled before tightening hardware. Recommended torque values for hardware are located on page 29.

ASSEMBLY TABLE OF CONTENTS

MAIN ASSEMBLY	16
ANGLE HYDRAULIC KIT KHCN101 (OPTIONAL)	19
HOSE ASSEMBLY WITH ANGLE HYDRAULIC KIT (OPTIONAL)	20

Assembly Cont'd

MAIN ASSEMBLY

The following instructions illustrate the steps to assemble the rear blade parts. We suggest to follow this sequence carefully. The rear blade assembly should be done by no less than two persons and the appropriate equipment for an easier assembling.

The following tools are necessary for assembling your rear blade:

- Two adjustable wrenches or:
 - One adjustable wrench and:
 - One 15/16 wrench or 15/16 ratchet
 - One 1 1/8 wrench or 1 1/8 ratchet
 - One 1 1/2 wrench or 1 1/2 ratchet
- One rubber mallet

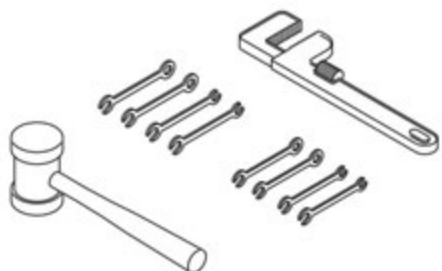

In some cases, it is necessary to use a steel mallet to install the pins. Therefore we recommend to use a piece of wood to get a softer impact between the pin and the mallet avoiding a possible damage to the pin.

WARNING

■ DANGER OF CUTTING EDGE FALLING

It could cause serious injuries or even death. Keep hands and feet out of cutting edge while it is up.



WARNING

■ DANGER OF BRUISING

Be careful with the pieces joined by pins since they tend to rotate.

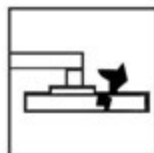

Assembly Cont'd

Remove Parts from Crate

NOTE: The shipping crate base can be used to aid in the assembly of the rear blade.

1. Remove top and sides from crate.
2. Remove box of parts and mechanical linkages from base.

1. Attach Main Frame to Turn Table.

Assemble the turn table (2) to the main frame (1) using the bolt (12), washer (17) and nut (16).

1. Main Frame
2. Turn Table
12. Bolt, 1 x 5 1/2 HHCS GR5
17. Flat Washer, 1
16. Lock Hex Nut, 1

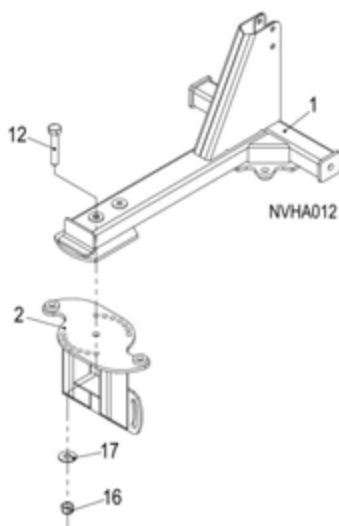

Figure 9. Turn Table Installed to Main Frame

2. Upper Turn Table Pin Installation.

Secure the turn table (2) to the main frame (1) using the pin (5) and the "R" safety pin (21).

1. Main Frame
2. Turn Table
5. Turn Table Pin
21. Safety Pin, 1/8

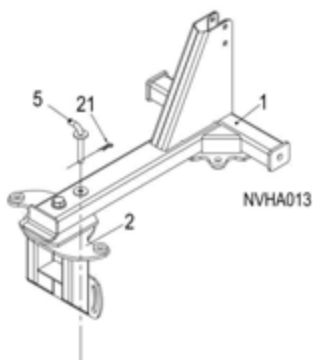

Figure 10. Upper Turn Table Pin Installation

Assembly Cont'd

3.- Mechanical offset.

Assemble the backing (3) to the moldboard back side (4) lining up the holes, using bolts (9) lock washers (18), and nuts (13). The backing position depends of the moldboard's offset angle you would like to use.

NOTE: The bolts (11) on step 4, must be placed on the backing (3) before install it.

3. Backing
4. Moldboard Assembly
9. Bolt, 5/8 x 1 1/2 HHCS GR5
13. Hex Nut, 5/8
18. Lock Washer, 5/8

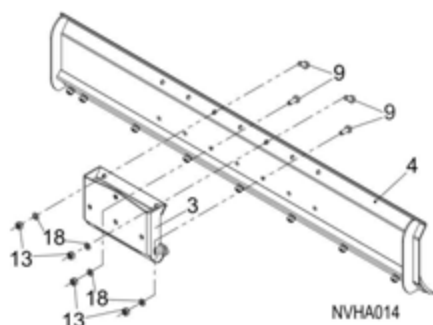

Figure 11. Mechanical Offset.

4.- Turn Table Installed to Moldboard.

Assemble the moldboard (4) through the backing (3) to the turntable (2), using bolts (11), washers (7), lock washers (19) and nuts (14). The angle of moldboard depends of the moldboard's tilt angle you would like to use.

2. Turn Table
3. Backing
4. Moldboard Assembly
7. Turn Table Washer
11. Bolt, 3/4 x 1 1/2 HHCS GR5
14. Hex Nut, 3/4
19. Lock Washer, 3/4

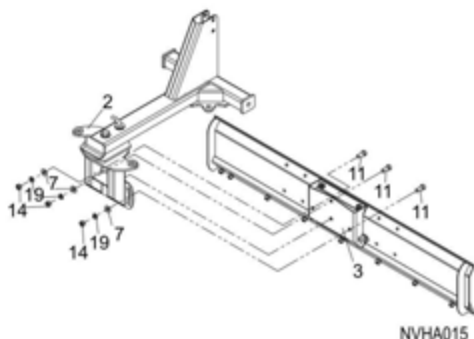

Figure 12. Turn Table Installes to Moldboard.

Assembly Cont'd

5.- 3-Point Hitch Mast and Main Frame Pin Installation

1. Insert the two lower hitch pins (8) through the main frame (1) ear holes and secure using lock washers (20), and hex nuts (15). Place the klik pins (22) into the lower hitch pins (8).

2. Insert the upper hitch pin (6) into the upper hole on the 3-Point hitch mast of main frame (1) and secure using a safety pin (21).

1. Main Frame
6. Upper Hitch Pin
8. Lower Hitch Pins
15. Hex Nuts
20. Lock Washers
21. Safety Pin, 1/8
22. Klik Pins

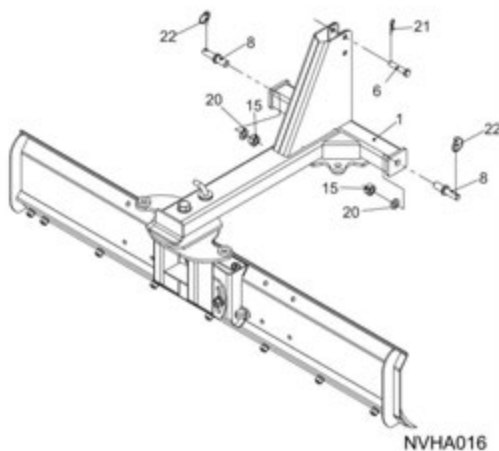

Figure 13. 3-Point Hitch Mast and Main Frame Pin Installation

Angle Hydraulic Kit KHCN101 (Optional)

A. Attach angle cylinder (A) to turn table (2) angle cylinder lug and main frame (1) angle cylinder lug. Secure with two clevis pins and two clevis pin retainers. Remove turn table pin (5) and safety pin (21).

1. Main Frame
2. Turn Table
5. Turn Table Pin
21. Safety Pin, 1/8

- Z. Cylinder SAE, 2 x 1/2 x 12 Kit
- A. Cylinder
- B. Pin
- C. Clevis Pin Retainer

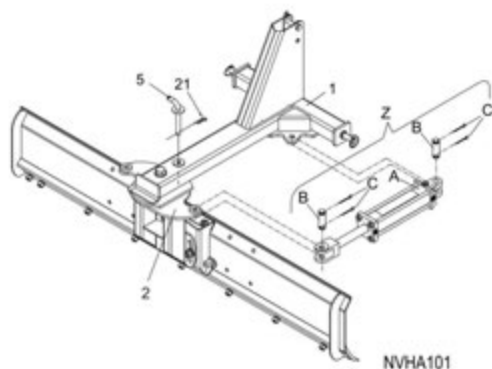

Figure 14. Angle Cylinder Installation

Assembly Cont'd

HOSE ASSEMBLY WITH ANGLE HYDRAULIC KIT (OPTIONAL)

Hose Assembly

B. Angle Hose Assembly (2.40m hoses) (8-foot hoses)

Direct hoses (2) as shown to the angle cylinder (1). Connect the female ends of the hoses to the male ends of the elbow fittings (3). Then connect the male ends of the elbow fittings (3) to the cylinder (1) ports.

C. General Hose Assembly

1. For each pair of hoses coming out of a cylinder (1), use two plastic straps (5) in order to keep the sets together.
2. Connect the two male quick couplers (4) to the hoses (2).

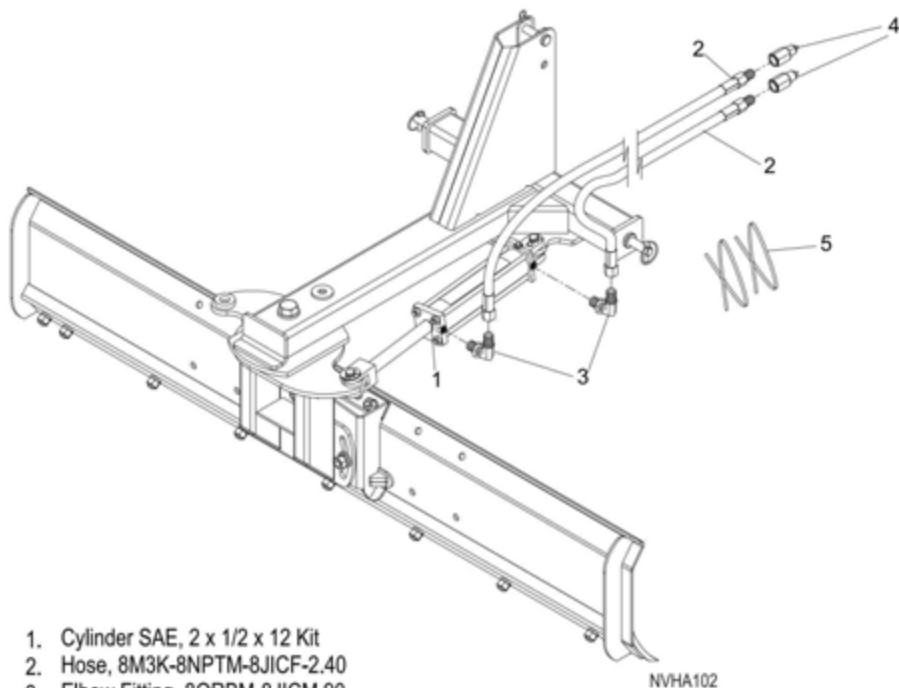

1. Cylinder SAE, 2 x 1/2 x 12 Kit
2. Hose, 8M3K-8NPTM-8JICF-2.40
3. Elbow Fitting, 8ORB-8JICM 90
4. Male Quick Coupler
5. Plastic Strap

Assembly Cont'd

PRE-DELIVERY CHECK LIST (DEALER'S RESPONSIBILITY)

Inspect the equipment thoroughly after assembly to ensure it is set up properly before delivering it to the customer.

The following check lists are a reminder of points to inspect. Check off each item as it is found satisfactory or after proper adjustment is made.

Check that all safety decals are installed and in good condition. Replace if damaged.

Check all bolts to be sure they are properly torqued.

Check that all cotter pins and safety pins are properly installed. Replace if damaged.

Check and grease all lubrication points.

DELIVERY CHECK LIST (DEALER'S RESPONSIBILITY)

Show customer how to make adjustments.

Point out the safety decals. Explain their meaning and the need to keep them in place and in good condition. Emphasize the increased safety hazards when instructions are not followed.

Instruct customer how to lubricate and explain importance of lubrication.

Present Operator's Manual and request that customer and all operators read it before operating equipment. Point out the manual safety rules, explain their meanings and emphasize the increased safety hazards that exist when safety rules are not followed.

Explain to customer that when equipment is transported on a road or highway, a Slow Moving Vehicle (SMV) sign should be used to provide adequate warning to operators of other vehicles.

NOTES

NOTES



PARTS INDEX

REAR BLADES

NVHA-180

NVHA-210

NVHA-240

NVHA-180/NVHA-210/NVHA-240 MAIN ASSEMBLY	25
MAIN ASSEMBLY PARTS LIST	26
ANGLE HYDRAULIC KHCN101 KIT (OPTIONAL)	27
ASSEMBLY & PARTS LIST	28
ANGLE HYDRAULIC CYLINDER (O)	28

NVHA-180 / NVHA-210 / NVHA-240 MAIN ASSEMBLY

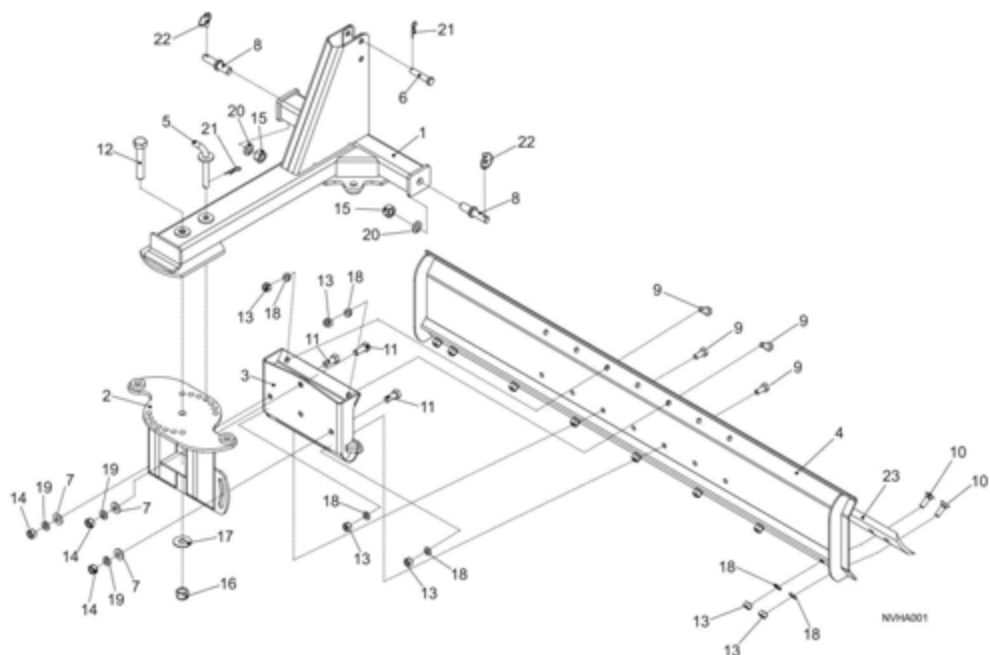

- 24. DECAL SET, SAFETY NVHA-180/210/240
- 25. DECAL SET, COMPLETE NVHA-180/210/240
- 26. OPERATOR'S MANUAL NVHA-180/210/240

MAIN ASSEMBLY PARTS LIST

REF	PART	QTY	DESCRIPTION
1	TACN07110100W	1	MAIN FRAME
2	TACN07110200W	1	TURN TABLE
3	TACN07110300W	1	BACKING
4	TACN06070400W	1	NVHA-180 MOLDBOARD ASSEMBLY (6 FT.)
	or		
4	TACN07110400W	1	NVHA-210 MOLDBOARD ASSEMBLY (7 FT.)
	or		
4	TACN08110400W	1	NVHA-240 MOLDBOARD ASSEMBLY (8 FT.)
5	TACN07110500W	1	TURN TABLE PIN
6	TACN07110001C	1	UPPER HITCH PIN
7	TACN07110002C	3	TURN TABLE WASHER
8	TACN06010001C	2	LOWER HITCH PIN
9	*	4	BOLT, 5/8 X 1 1/2 HHCS GR5
10	*	†	PLOW BOLT, 5/8 X 2 GR5
11	*	3	BOLT, 3/4 X 1 3/4 HHCS GR5
12	*	1	BOLT, 1 X 5 1/2 HHCS GR5
13	*	††	HEX NUT, 5/8 - 11
14	*	3	HEX NUT, 3/4 - 10
15	*	2	HEX NUT, 1 - 8
16	*	1	LOCK HEX NUT, 1 - 8
17	*	1	FLAT WASHER, 1
18	*	††	LOCK WASHER, 5/8
19	*	3	LOCK WASHER, 3/4
20	*	2	LOCK WASHER, 1
21	*	2	SAFETY PIN, 1/8
22	*	2	KLIK PIN, 3/8
23	TA4370-1030-00	1	6 FT. CUTTING EDGE
	or		
23	TA4370-1050-00	1	7 FT. CUTTING EDGE
	or		
23	TA4370-1070-00	1	8 FT. CUTTING EDGE
24	TACN07110015K		DECAL SET, SAFETY NVHA-180/210/240
25	TACN07110016K		DECAL SET, COMPLETE NVHA-180/210/240
26	TACN07110017K		OPERATOR'S MANUAL NVHA-180/210/240
		†	8 FOR NVHA-180, 9 FOR NVHA-210, 10 FOR NVHA-240
		††	12 FOR NVHA-180, 13 FOR NVHA-210, 14 FOR NVHA-240
		*	Standard Hardware; Obtain Locally

ANGLE HYDRAULIC KHCN101 KIT (OPTIONAL)

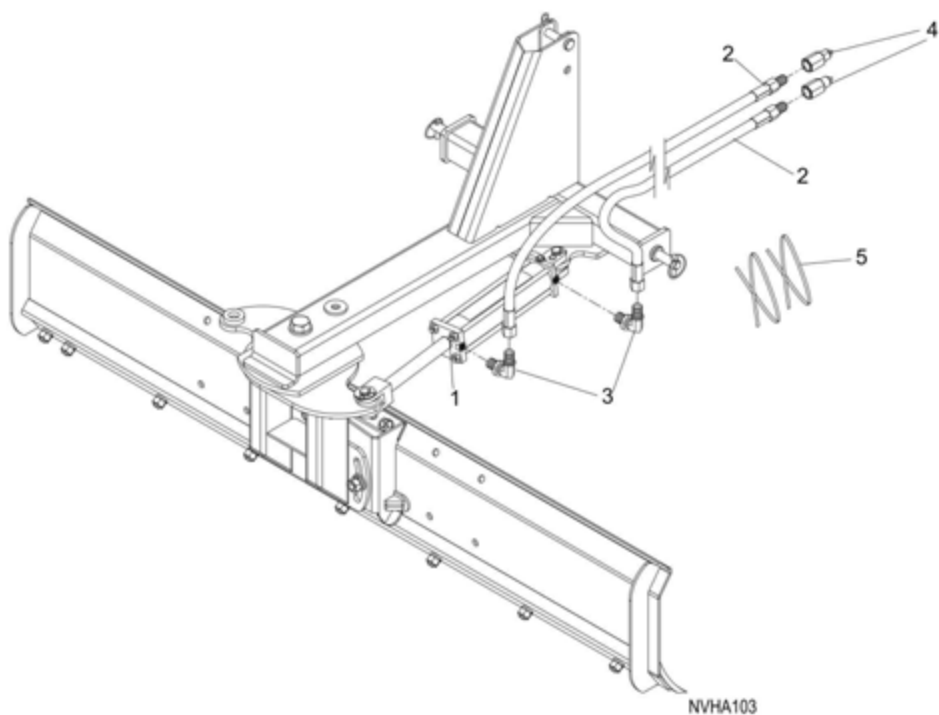

REF	PART	QTY	DESCRIPTION
1	TA4110-4032-01	1	CYLINDER SAE 2 1/2 X 12 KIT (B250120ABAAA07B)
2	TA4430-1567-40	2	HOSE, 8M3K-8NPTM-8JICF- 2.40
3	TA4120-1159-50	2	ELBOW FITTING, 8ORBM-8JICM 90
4	*	2	MALE QUICK COUPLER
5	*	2	PLASTIC STRAP

* Standard Hardware; Obtain Locally

ANGLE HYDRAULIC CYLINDER ASSEMBLY & PARTS LIST

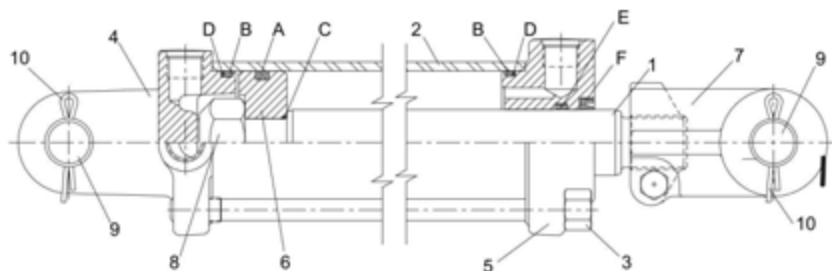
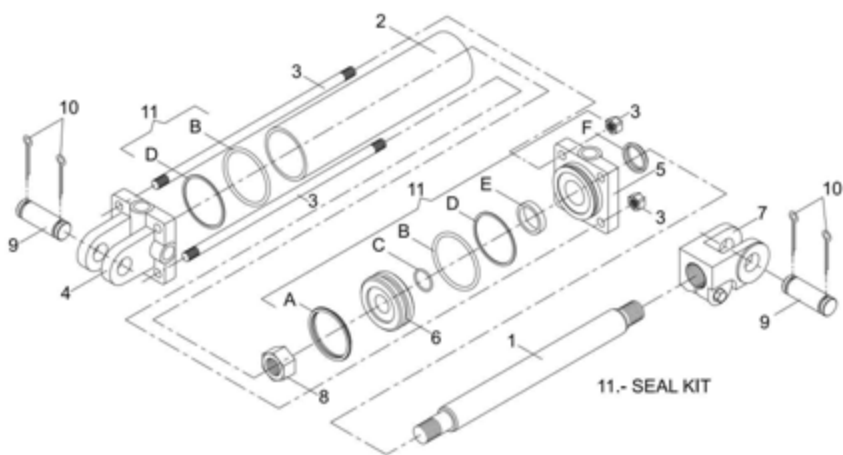

NV/HA104

REF	PART	QTY	DESCRIPTION
1	TA4110-4032-05	1	PISTON ROD
2	TA4110-4033-05	1	TUBE
3	TA4110-4034-05	4	TIEROD ASSEMBLY WITH NUT
4	TA4110-4035-05	1	BUTT
5	TA4110-4036-05	1	GLAND
6	TA4110-4037-05	1	PISTON
7	TA4110-4053-05	1	CLEVIS ASSEMBLY
8	TA4110-4054-05	1	LOCKNUT, 1.00 - 14
9	TA4110-4055-05	2	CLEVIS PIN
10	TA4260-1100-01	4	CLEVIS PIN RETAINER
11	TA4110-4038-05	1	SEAL KIT
A		1	CROWN SEAL
B		2	O-RING
C		1	O-RING
D		2	BU-WASHER
E		1	U-CUP
F		1	WIPER

* Standard Hardware; Obtain Locally

BOLT TORQUE CHART

Always tighten hardware to these values unless a different torque value or tightening procedure is listed for a specific application.

Fasteners must always be replaced with the same grade as specified in the manual parts list.

Always use the proper tool for tightening hardware: SAE for SAE hardware and Metric for metric hardware.

Make sure fastener threads are clean and you start thread engagement properly.

All torque values are given to specifications used on hardware defined by SAE J1701 & J1701M JUL96.

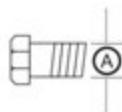

SAE SERIES TORQUE CHART



SAE Bolt Head Identification



Diameter (Inches)	Wrench Size	MARKING ON HEAD					
		SAE 2		SAE 5		SAE 8	
		Lbs.-Ft.	N-m	Lbs.-Ft.	N-m	Lbs.-Ft.	N-m
1/4"	7/16"	6	8	10	13	14	18
5/16"	1/2"	12	17	19	26	27	37
3/8"	9/16"	23	31	35	47	49	67
7/16"	5/8"	36	48	55	75	78	106
1/2"	3/4"	55	75	85	115	120	163
9/16"	13/16"	78	106	121	164	171	232
5/8"	15/16"	110	149	170	230	240	325
3/4"	1-1/8"	192	261	297	403	420	569
7/8"	1-5/16"	306	416	474	642	669	907
1"	1-1/2"	467	634	722	979	1020	1383

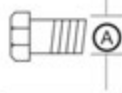

METRIC SERIES TORQUE CHART



Metric Bolt Head Identification



Diameter & Thread Pitch (Millimeters)	Wrench Size	COARSE THREAD				FINE THREAD				Diameter & Thread Pitch (Millimeters)
		MARKING ON HEAD								
		Metric 8.8		Metric 10.9		Metric 8.8		Metric 10.9		
		N-m	Lbs.-Ft.	N-m	Lbs.-Ft.	N-m	Lbs.-Ft.	N-m	Lbs.-Ft.	
6 x 1.0	10 mm	8	6	11	8	8	6	11	8	6 x 1.0
8 x 1.25	13 mm	20	15	27	20	21	16	29	22	8 x 1.0
10 x 1.5	16 mm	39	29	54	40	41	30	57	42	10 x 1.25
12 x 1.75	18 mm	68	50	94	70	75	55	103	76	12 x 1.25
14 x 2.0	21 mm	109	80	151	111	118	87	163	120	14 x 1.5
16 x 2.0	24 mm	169	125	234	173	181	133	250	184	16 x 1.5
18 x 2.5	27 mm	234	172	323	239	263	194	363	268	18 x 1.5
20 x 2.5	30 mm	330	244	457	337	367	270	507	374	20 x 1.5
22 x 2.5	34 mm	451	332	623	460	495	365	684	505	22 x 1.5
24 x 3.0	36 mm	571	421	790	583	623	459	861	635	24 x 2.0
30 x 3.0	46 mm	1175	867	1626	1199	1258	928	1740	1283	30 x 2.0

Typical Washer Installations



BOLT SIZE CHART

NOTE: Chart shows bolt thread sizes and corresponding head (wrench) sizes for standard SAE metric bolts.

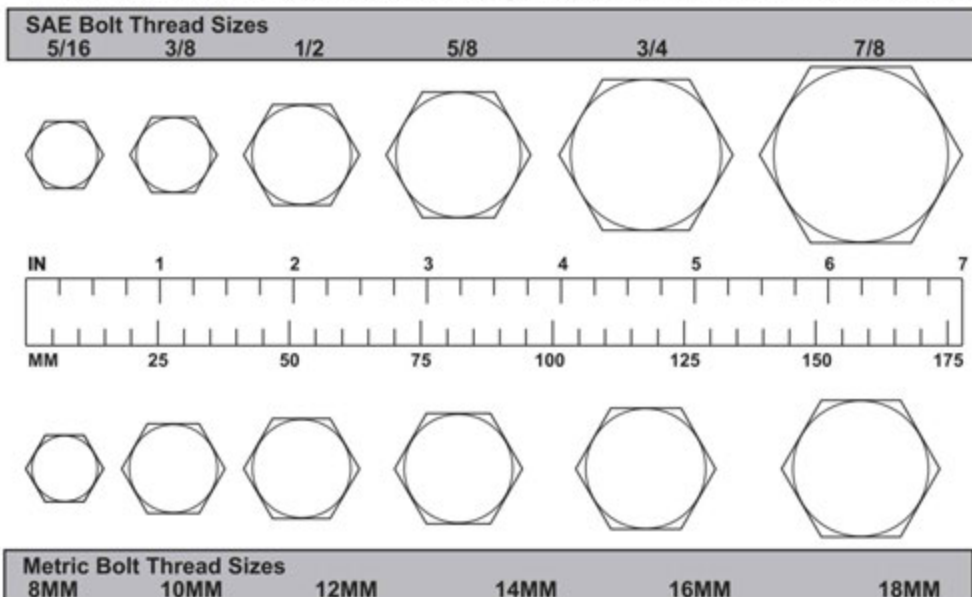

ABBREVIATIONS

AG	Agriculture	NC	National Coarse
ATF	Automatic Transmission Fluid	NF	National Fine
BSPP	British Standard Pipe Parallel	NPSM	National Pipe Straight Mechanical
BSPTM	British Standard Pipe Tapered Male	NPT	National Pipe Tapered
CV	Constant Velocity	NPT SWF	National Pipe Tapered Swivel Female
CCW	Counter-Clockwise	ORB	O-Ring Boss - Male
CW	Clockwise	P	Pitch
F	Female	PBY	Power Beyond
GA	Gauge	psi	Pounds per Square Inch
GR (5, etc.)	Grade (5, etc.)	PTO	Power Take Off
HHCS	Hex Head Cap Screw	QD	Quick Disconnect
HT	Heat Treated	RH	Right Hand
JIC	Joint Industry Council 37° Degree Flare	ROPS	Roll Over Protective Structure
LH	Left Hand	RPM	Revolutions Per Minute
LT	Left	RT	Right
m	Meter	SAE	Society of Automotive Engineers
mm	Millimeter	UNC	Unified Coarse
M	Male	UNF	Unified Fine
MPa	Mega Pascal	UNS	Unified Special
N	Newton		

WARRANTY

Please enter information below and save for future reference.

Date Purchased: _____ From (Dealer): _____

Model Number: _____ Serial Number: _____

A. GENERAL PROVISIONS - The warranties described below are provided by Tecnomec Agrícola, S.A. de C.V. (TECNOMECE) to the original purchasers of new agricultural products from TECNOMECE or authorized dealers for a period of one (1) year **under agricultural use**. Replacement or repair parts installed in the equipment covered by this limited warranty are warranted for ninety (90) days from the date of purchase of such part or the expiration of the applicable new equipment warranty period, whichever occurs later. Under these warranties, TECNOMECE will repair or replace, at its discretion, any covered part which is found to be defective in material or workmanship during the applicable warranty term. Warranty service must be performed by an authorized BISON dealer, which will use only new or remanufactured parts or components furnished by TECNOMECE.

Warranty service will be performed without charge to the purchaser for parts or labor. The purchaser will be responsible, however, for any service call and/or transportation of product to and from the dealer's or service center's place of business, for any premium charged for overtime labor requested by the purchaser, and for any service and/or maintenance not directly related to any defect covered under the warranties below. At TECNOMECE's request, dealer will be responsible for returning the parts to TECNOMECE for evaluation.

B. WHAT IS WARRANTED - All parts of any new TECNOMECE product. TECNOMECE makes no warranty, express or implied, with respect to engines, batteries, tires or other parts or accessories not manufactured by TECNOMECE. Warranties for these items, if any, are provided separately by their respective manufacturers.

Each warranty term begins on the date of product delivery to the purchaser.

C. WHAT IS NOT WARRANTED TECNOMECE IS NOT RESPONSIBLE FOR THE FOLLOWING : (1) Used Products; (2) Any product that has been altered, modified, or used in connection with attachments in ways not approved by TECNOMECE; (3) Depreciation or damage caused by normal wear, lack of reasonable and proper maintenance, failure to follow the product's OPERATOR MANUAL instructions, misuse, lack of proper protection during storage, or accident; (4) Normal maintenance parts and service, including, but not limited to, oil filters, coolants and conditioners, cutting parts, belts, brake and clutch linings.

Incidental or consequential losses, damages or expenses, arising directly or indirectly from the product, whether such claim is based upon breach of contract, breach of warranty, negligence, strict liability in tort or any other legal theory. Without limiting the generality of the foregoing, TECNOMECE specifically disclaims responsibility for any damages relating to (i) lost profits, business, revenues or goodwill; (ii) loss of crops; (iii) loss because of delay in harvesting; (iv) any expense or loss incurred for labor, supplies, substitute machinery or rental; or (v) any other type of damage to property or economic loss.

This Warranty is extended solely to the original purchaser of the product. Should the original purchaser sell or otherwise transfer this product to a third party, this Warranty does not transfer to the third party purchaser in any way. There are no third party beneficiaries of this Warranty.

D. SECURING WARRANTY SERVICE - To secure warranty services, the purchaser must (1) report the product defect to an authorized dealer and request repair within the applicable warranty term, (2) present evidence of the warranty start date, and (3) make the product available to the dealer or service center within 45 days.

E. NO IMPLIED WARRANTY OR OTHER REMEDY - AGRICULTURAL PRODUCTS - Where permitted by law, neither TECNOMECE nor any company affiliated with it makes any warranties, representations, or promises, express or implied as to the quality or performance, or freedom from defect of its agricultural products other than those set forth above, and **NO IMPLIED WARRANTY OF MERCHANTABILITY OR FITNESS FOR A PARTICULAR PURPOSE IS MADE. IN NO EVENT WILL THE DEALER, TECNOMECE OR ANY COMPANY AFFILIATED WITH TECNOMECE BE LIABLE FOR INCIDENTAL OR CONSEQUENTIAL DAMAGES.**

The only remedies the purchaser has in connection with the breach of performance of any warranty on TECNOMECE agricultural products are those set forth above.

F. NO WARRANTY MODIFICATION - No agent, representative, authorized dealer, distributor, service center, serviceperson, salesperson, other than an officer from TECNOMECE is authorized to alter, modify, or enlarge this Warranty.

G. If further information is desired, contact your selling dealer or the nearest branch office of TECNOMECE

H. This Warranty is effective only if the warranty registration is electronically submitted to TECNOMECE by dealer within ten (10) days of retail purchase date.

For warranty services contact your selling dealer.

NOTES

No. DE PARTE
4350-2109-00



