

McHale 995 L+T

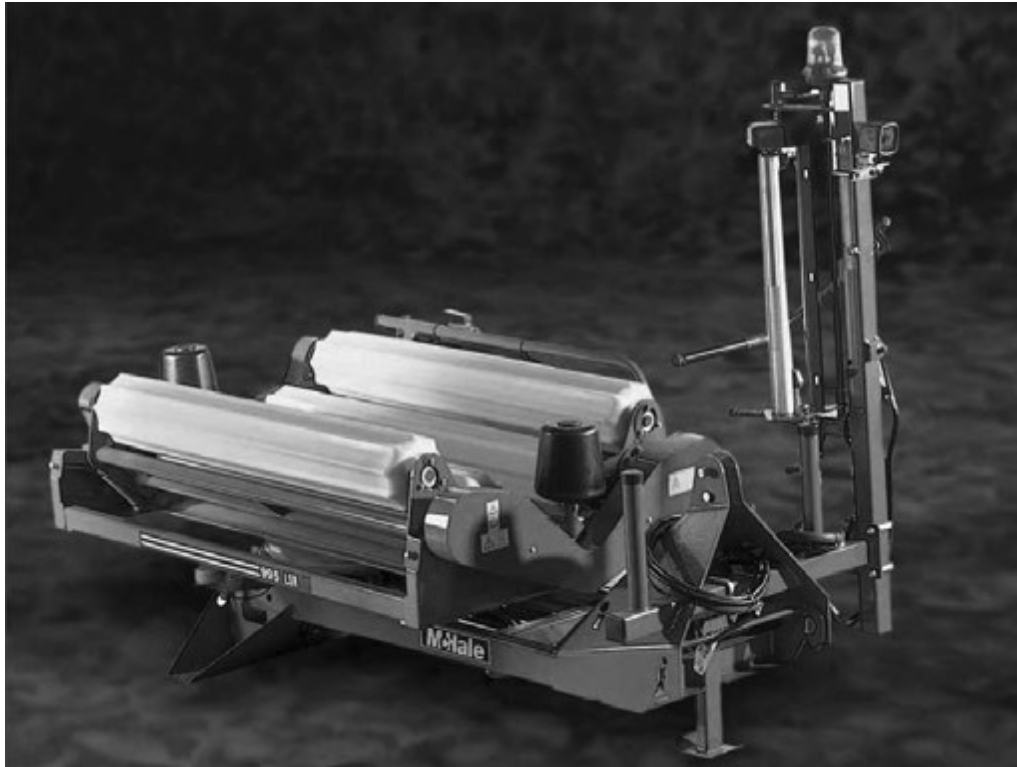

995 L+T Series Square Bale Wrapper

Operator Instructor Manual

Issue 8

McHale
Ballinrobe
Co. Mayo, Ireland

Tel: +353 94 9520300
Fax: +353 94 9520356
Email: sales@mchale.net
Website: www.mchale.net



This page is intentionally blank

McHale 995 L+T Square Bale Wrapper

Thank you for buying this **McHale** machine, you have chosen wisely!
Given proper care and attention, you can expect it to provide you with
years of dependable service.

Warranty/Guarantee

Attention End User!

Please ensure your machine is fully registered with **McHale**,
by your dealer, at the time of delivery.
Failure of the dealer to register the machine will render your warranty void!
You can check the registration of your machine by visiting **www.mchale.net**.

It is important to quote the machine serial number when ordering spare parts or
requesting technical assistance. Space is provided below to record machine details.

Serial number:	
Year of manufacturer:	
Date of delivery:	

If you require further copies of this instruction manual,
please quote part number: CLT00006

This manual covers the following machine variants (Not all variants are available in all
countries):

995 L	Linkage machine with manual controls and no cut and hold
995 LS	Linkage machine with manual controls
995 LSR	Linkage machine using full electronic control with remote control option
995 TS	Trailed machine using full electronic control
995 TSR	Trailed machine using full electronic control with remote control option

Due to a policy of continuous product development and improvement, **McHale**
Engineering reserves the right to alter machine specifications without prior notice and
any obligation to make changes or additions to the equipment previously sold.

Please note that all specifications marked with an  in this manual only relate to
certain models or optional equipment. Also these specifications may not be available
in all countries.

It is vital to replace defective parts of the machine immediately and to use only genuine
McHale spare parts, as these are designed and manufactured to the same standard
as the original machine. Spare parts can be obtained from your **McHale** dealer.

Table of Contents

1	Introduction	6
2	Product Information	7
2.1	Designated use of the machine	7
2.2	Front view	8
2.3	General Dimensions & specifications	9
2.4	Tractor attachment	9
2.5	Machine specifications	9
2.6	General dimensions & specifications	10
2.7	Tractor attachment	10
2.8	Machine specifications	10
3	General Safety	11
3.1	Be aware of all safety information	11
3.2	Follow all safety instructions	11
3.3	Store all items carefully	12
3.4	Protective clothing	12
3.5	In case of emergencies	12
3.6	Stay clear of moving parts	12
3.7	In the event of a fire	12
3.8	General safety warnings	13
4	Specific Safety Warnings	16
4.1	Electronic safety warnings	16
4.2	Hydraulic safety warnings	16
4.3	Noise level	17
4.4	Fire precautions	17
4.5	Safety instruction decal locations	18
4.6	Safety warnings & instructions explained	19
4.7	Machine lifting guidelines	22
5	Tractor Requirements & Preparation	23
5.1	Tractor/power pack requirements	23
5.2	Hydraulic spool valve setup	24
5.3	Attaching the wrapper (L Series)	25
5.4	Attaching the wrapper (T Series)	25
5.5	Connecting the control box	26
6	Bale & Plastic Film Requirements	27
6.1	Bale Requirements	27
6.2	Plastic Film Requirements	28
6.3	Care of the film roll	29
7	Manual Controls (995 L & LS)	30

McHale 995 L+T Square Bale Wrapper

8	Electronic Control System	31
8.1	Bale Wrap Computer (995 L & 995 LS)	31
8.2	Electronic Control Box (995 LSR, TS & TSR)	40
8.3	Electronic Control Box Functions	41
8.4	Available wrapping programs	42
8.5	Electronic Control Box Setup	43
8.6	Electronic Control Box Features	44
9	Wrapper Operation	52
9.1	Preparing the machine for wrapping	52
9.2	Loading plastic film	53
9.3	Wrapping at the stack with remote control	53
10	Road Traffic Safety & Operation	55
10.1	Before travelling on any public roadway	55
11	Field Operation & Wrapper Adjustments	57
11.1	Drawbar height	57
11.2	Dispenser height	57
11.3	Table stop position magnet (Program R94 load position - 995 LSR & TSR)	58
11.4	Table load position magnet (SR94 Program - 995 LSR & TSR)	59
11.5	Table half tip magnet (995 LSR & TSR)	60
11.6	Gearbox cross shaft roll pin replacement	61
11.7	Cut & hold adjustment	61
11.8	Cut & hold accumulator pressure	62
11.9	Chain adjustments	63
12	Accessories & Optional Equipment	66
12.1	Side Tip Damper	66
12.2	Remote control kit for static machine operation (995 LSR & TSR)	66
12.3	Dispenser Gears	67
13	Machine Maintenance	68
13.1	Maintenance intervals	68
13.2	Tightening torque values	71
14	Storage	72
14.1	End of season	72
14.2	Start of season	72
15	Trouble Shooting	73
15.1	Trouble shooting overview	73
16	Certification & Warranty	77
16.1	Declaration of Conformity	77
16.2	PDI Form	77
16.3	Change of ownership pre-checks	77
16.4	Limited Warranty	77

1

Introduction

The **McHale 995 L+T** Square Bale Wrapper is designed to wrap, with plastic stretch film, rectangular/square bales of forage for the purpose of storage as fodder for livestock. This wrapper can also wrap round bales with equal efficiency. The design has been developed based on years of extensive research and development in the field of bale wrappers. Given proper care and attention, the **McHale 995 L+T** will provide years of reliable and dependable performance.

Please do not assume that you know how to operate and maintain your machine before reading this manual carefully. In order to prevent misuse, damage and accidents, it is very important that everybody who will operate the **McHale 995 L+T** be a fully trained operator. They must read and fully understand all of the contents of this manual, before operating the machine, paying particular attention to the following:

- Safety instructions
- Functions
- Controls (hydraulic & electrical)

It is highly recommended to get acquainted with any new machinery slowly. Take time to learn and understand all of the features of the machine. Proficiency will increase as more experience is obtained.

If you have any questions in relation to the instructions in the manual, please contact your **McHale** dealer. It is highly recommended that training be sought from your local **McHale** dealer.

The operator is solely responsible for the safe use and maintenance of the machinery, in accordance with this manual. Keep this manual safe and make sure it remains with the machine, at all times.

2

Product Information

The **McHale 995 L+T** is protected against many dangers to itself while being operated from the control box, in manual and fully automatic modes. However, it is of the utmost importance for the safety of the operator and for others, that the operator pays attention to all warnings and instructions given in this manual. In particular all safety devices, decals, guards and controls must be in place and in fully functioning condition. Never try to clear any malfunction when the tractor is switched on or while the machine is running. Keep the “Danger Zone” (An area around the machine, detailed in “Danger Zone” on page 13) free of all persons and animals at all times, while the machine is in operation. This manual must be read and fully understood by anyone who will operate the machine.

2.1 Designated use of the machine

The **McHale 995 L+T** is exclusively designed for normal use in agricultural applications. The machine has been designed to wrap rectangular/square bales of forage with plastic stretch film for the purpose of storing as fodder for feeding livestock. This wrapper can also wrap round bales with equal efficiency. This designation includes the movement of the machine, between fields by track or road, incidental to the square wrapper’s main use. The manufacturer will not be held responsible for any loss or damage resulting from machine applications other than those specified above. Any other use the machine may be put to, is entirely at the owners/operators risk.

The designated use of the machine includes that:

- the operating, maintenance and repair instructions given by the manufacturer will be strictly fulfilled
- exclusively persons who are familiar with it and instructed about the risks are entitled to operate, maintain and/or repair the machine
- the relevant health and safety requirements, that may be in force in the country of use, will be strictly followed
- no other equipment or accessories, other than released by **McHale**, are installed in the machine. The use of any other equipment or accessory is entirely at the owner/operators risk. In such cases, unauthorised modifications/changes exclude any liability of the manufacturer.



WARNING: Loss of machine validity

By any alteration of safety equipment, the declaration of conformity and the CE sign loses it’s validity for this machine.

2.2 Front view

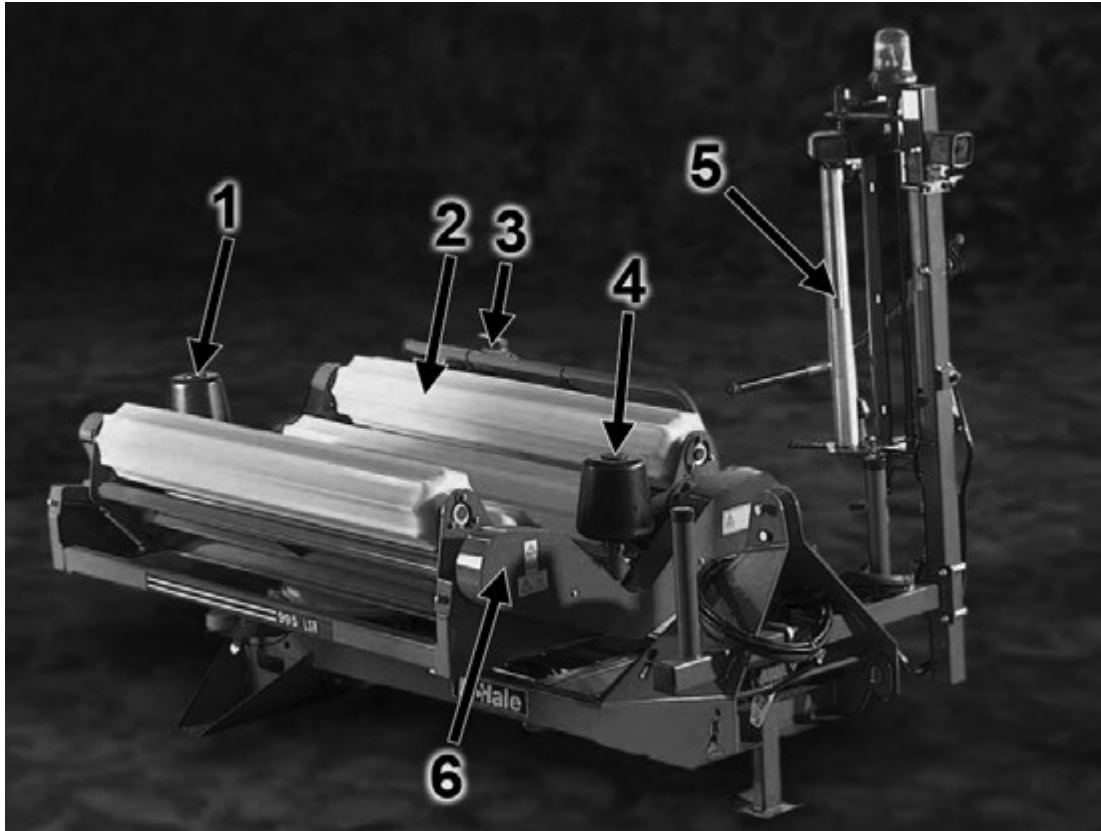

No.	Machine Function
1	Bale Support Bobbin
2	Rotating Table
3	Cut and Hold
4	Bale Support Bobbin
5	Quick Fit Dispenser
6	Shear Bolt Unit

L Series

2.3 General Dimensions & specifications

Units are given in both metric and UK imperial values, with the latter shown in brackets.

Transport length	3.1 m (10'2")
Transport width	1.73 m (5' 8")
Transport height	1.97 m (6' 6")
Height to top of rollers	0.97 m (3' 2")
Transport weight (unladen)	1,050 kg (2,315 lbs)

2.4 Tractor attachment

Attachment	Category 2, three point linkage
Electrics	12 Volt DC, 7 amp approx.
Hydraulic systems	Load sensing, open centre, closed centre
Minimum hydraulic pressure	160 bar (2,350 psi)
Minimum hydraulic flow rate	18 l/min (4 gal/min)
Maximum rotary table speed	30 rpm

2.5 Machine specifications

Film stretch	55% (64% optional)
Film layers	2+2 system
Film width	750 mm
Maximum bale size (Square)	W: 800-900 mm, H: 600-1,000 mm, L: 1,800 mm
Maximum bale size (Round)	W: 1,500 mm, D: 1,500 mm
Maximum bale weight	1,000 kg (2,205 lbs)

T Series

2.6 General dimensions & specifications

Transport length	3.5 m (11' 6")
Transport width	1.91 m (6' 3")
Transport height	2.00 m (6' 7")
Height to top of rollers	0.97 m (3' 2")
Transport weight (unladen)	1,150 kg (2,535 lbs)
Tyre dimensions	20.5 x 8.00 -10
Tyre pressure	3.4 bar/50 psi
Maximum road speed	40 km/h (25 mph)

Check with national road traffic regulations in the individual country!

2.7 Tractor attachment

Attachment	Pin hitch
Towing tractor requirements	35 kw
Electrics	12 Volt DC, 7 amp approx.
Hydraulic systems	Load sensing, open centre, closed centre
Minimum hydraulic pressure	160 bar (2,350 psi)
Minimum hydraulic flow rate	18 l/min (4 gal/min)
Maximum rotary table speed	30 rpm

2.8 Machine specifications

Film stretch	55% (64% optional)
Film layers	2+2 system
Film width	750 mm
Maximum bale size (Square)	W: 800-900 mm, H: 600-1,000 mm, L: 1,800 mm
Maximum bale size (Round)	W: 1,500 mm, D: 1,500 mm
Maximum bale weight	1,000 kg (2,205 lbs)

3

General Safety

3.1 Be aware of all safety information

Follow all safety precautions and practice safe operation of machinery, at all times.

Warning, Caution, Information & Environmental Messages:

When reading this manual, pay particular attention when you see the symbols below i.e. Warning, Caution, Information & Environmental. They will be used at various points in this manual and may also appear on safety decals on the machine. The purpose of these messages are to ensure that the most important information stands out from the rest of the text.



WARNING: This symbol indicates a potentially hazardous situation, that if not avoided could result in machinery damage, personal injury or even death.



CAUTION: This symbol indicates a potentially hazardous situation, that if not avoided could result in machinery damage or personal injury.



INFORMATION: This symbol is used to identify special instructions or procedures which, if not followed strictly, could result in machinery damage.



ENVIRONMENTAL: reminds you to respect the environment in relation to the correct disposal of waste material

3.2 Follow all safety instructions



Using this manual, read all safety instructions, messages and be aware of the meanings of all safety decals. If safety decals are damaged or missing due to wear and tear or component replacement, ensure that they are replaced by genuine **McHale** decals. Refer to the Decals Section in this manual (or spare parts book provided) to see the spare part codes for the relevant decals, which are available from your **McHale** dealer.

As with all machinery, learn all operations and use controls by reading this manual thoroughly. Do not attempt to let anyone operate this machine without being fully instructed.

3.3 Store all items carefully



Store all attachments such as films rolls and any other stored items in a secure and safe manner so as to prevent items from falling. Keep storage areas clear of bystanders and children.

3.4 Protective clothing



Always wear clothing and safety equipment that is fit for the job at hand, never wear loose clothing. In the event of loud noises, wear suitable protective hearing devices. Use of mobile phones or radio/music headphones are not recommended while operating machinery as these impair the operator's attention.

3.5 In case of emergencies



In the event of any accident, emergency equipment should be kept close at hand. A first aid kit and fire extinguisher along with emergency phone numbers should always be available to machine operators.

3.6 Stay clear of moving parts

Serious injury or death can result from entanglement of clothing or body parts with Check for smooth operation of the table and all moving parts.

Keep all guards in place at all times, only wear close fitting clothing and ensure that tractor engine has stopped and key is removed before carrying out any adjustments, connections or cleaning of equipment.

3.7 In the event of a fire



In the event of a fire, the following is given, only as a guideline procedure, as it is the operator's decision to ascertain the seriousness and hence the solution to the situation.

1. Immediately tip the bale off the table and move the tractor and wrapper away from the flammable material.
2. Shutdown the tractor and remove the key from the ignition.
3. Remove all hydraulic hosing and electrical looms from the machine.

McHale 995 L+T Square Bale Wrapper

4. With all connections removed, disengage the wrapper from the tractor.
5. Drive the tractor away from the wrapper.
6. Using a suitable fire extinguisher, attempt to put out the fire.



NOTE: Fire Prevention

It is recommended that the wrapper be kept reasonably clean and free of build-ups of crop, lubricants, etc. This will help to reduce the risk of fires.

3.8 General safety warnings

Read and understand this operator manual before using the machine. If any of the instructions appear unclear do not hesitate to contact your **McHale** dealer.

Only competent persons who have read and fully understood this manual are qualified to operate this machine. The owner of this machine is obliged, by law, to ensure that every operator understands all of the functions, controls, working processes and safety warnings, before operating the machine.

Safety Devices

- All safety devices such as guards, protection parts and safety controls must be in place and in fully functioning condition. It is forbidden to operate this machine with defective or incomplete safety devices.

Danger Zone

- The 'Danger Zone' is the area around the rotating table (approx. 5 metres radius from the rotating centre axis), 1 metre in front of the table and a minimum of 10 metres at the back of the machine to allow for safe bale discharge.



NOTE: "Danger Zone" can vary in size

The operator must be aware of the 'Danger Zone' which can vary in size, depending on operating conditions, i.e. hilly terrain.

- It is the operator's responsibility to ensure that there is no person in the '**Danger Zone**' while operating the machine, especially during start up.

Before Repair or Reassembly

- Safe lifting gear of sufficient capacity must be used for machine assembly. All chains and slings used must be in good condition.

Before Operation

- The operator must ensure that the manufacturer's instructions for attaching and detaching the machine from the tractor or hydraulic power pack. This includes the use and fitment of lights, if necessary.
- The operator must ensure that all safety devices are in operating mode

McHale 995 L+T Square Bale Wrapper

- The operator must ensure that there is no person in the “Danger Zone”
- Always be familiar with the health and safety requirements that may be in force in the country of use

During Operation

- While operating this machine on hilly or sloping ground the operator must take extra precautions, in particular the “Danger Zone” is increased in such conditions as bales are more likely to roll away, causing a potential risk.
- Always keep children and spectators well away from the working area of the machine
- The operator must ensure that there is a minimum of 4 m clearance between the machine and any obstacle above, in particular electrical high voltage lines.
- Be careful when working with the cut & hold. Remember that the accumulators are under pressure.
- Avoid contact with the knife
- Do not attempt to clamp plastic film in the cut & hold mechanism
- Particular care must be taken, if the machine is left idle for any extended period, to ensure that all sensors and safety features are working correctly.
- The safety bar must always be used when working under a tipped table



WARNING: Do not carry people or animals on the machine

The operator must ensure that no persons or animals are carried on the machine at any time or are hidden under the machine (on the tractor persons are only allowed to sit on the relevant seats)

Before Travelling On Public Roads

- The owner of this machine is obliged by law to ensure that every operator has got a valid driving licence and is familiar with the road traffic regulations relating to the country of use.
- Always ensure that the electronic control box or bale wrap computer and oil supply are switched off
- Ensure lights (if fitted) are connected and working correctly
- If plastic film is to be transported on the machine it must only be done so on the holders provided and secured, if necessary.
- Adjust driving speed to suit ground conditions
- Allow for mounted machines reducing front end weight on the tractor

Performing Maintenance

- Maintenance and repair work on the **995 L+T** should always be carried out in accordance with this manual.
- Maintenance and repair work exceeding the content of this manual should only be carried out by qualified persons or your **McHale** dealer.
- When conducting maintenance work tie long hair behind your head. Do not wear a necktie, necklace, scarf or loose clothing when you work near the machine or moving parts. If these items were to get caught, severe injury could result.
- Before working on this machine, such as replacing film rolls or altering any setting, the operator must ensure the following:
 - (a) The tractor has definitely stopped moving
 - (b) The hand brake is applied
 - (c) The engine is shut down
 - (d) The ignition key is removed
 - (e) Electronic power supply and control box is disconnected
 - (f) Hydraulic oil supply is switched off

**It is forbidden to carry out any work on the machine, unless the above specified precautions have been carried out.*
- When conducting maintenance work always support the machine properly. Where possible, lower the attachment or implement to the ground before you work on the machine. If it is not possible to lower the machine or attachment to the ground, always securely support the machine or attachment. Do not work under a machine that is solely supported by a jack. Never support the machine with props that may break or crumble under continuous load.
- Never disable any electrical safety circuits, tamper with safety devices or carry out any unauthorised modification to the machine.
- Avoid heating near pressurised fluid lines, as pressurised lines can be accidentally damaged when heat goes beyond the immediate flame area.

During inspection

- If carrying out an inspection during machine operation within the “Danger Zone” (**highly dangerous and NOT recommended!**), then there should be a fully trained and competent second person operating both the tractor and wrapper controls. If at any time the second operator loses sight of the inspector, turn off all tractor power immediately! Such inspection should only be carried out if all guards are fully in place, the machine is on level ground and a safe distance is kept from any hazards on the machine.

4

Specific Safety Warnings

4.1 Electronic safety warnings

- This machine is equipped with electronic parts and components which comply to the EMC directive 2004/108/CE but still may be influenced by electromagnetic transmissions of other apparatus, such as welding machines, etc.
- Check electric cables regularly for signs of breakage or wear. If in doubt always replace (faulty safety circuits will cause risks).
- Do not modify any safety circuits

4.2 Hydraulic safety warnings

- The maximum pressure in the hydraulic system of this machine should not exceed 210 bar.
- Always ensure the system is not under pressure before working on the machine. Oil under pressure can penetrate the skin and cause injury.
- Hydraulically actuated devices, such as the table tip must be blocked mechanically against movement, before working on the machine.
- If any hoses are removed or replaced ensure they are marked and re-installed to the correct position during re-assembly.
- Check hoses regularly for signs of leakage or wear. Use a piece of card when checking for leaks. Fine jets of hydraulic fluid can penetrate the skin. Never use your fingers or face to check for leaks. If in doubt always replace. The recommended maximum working time of hoses should not exceed 5 years. Only use exact specification **McHale** genuine replacement parts.
- As the cut and hold is kept open by gas accumulator pressure, it will be necessary to release this before removing the accumulator or working on the hydraulic cylinder. Otherwise injury may occur. If in doubt entrust the job to your **McHale** dealer.
- Do not work on hydraulic systems unless you are qualified to do so. This work should only be carried out by qualified persons or your **McHale** dealer.

4.3 Noise level

- The European Regulation 86/188/EEC directs employers and employees to control the noise level at work. The noise level at field work may differ according to the tractor, ground, crops and other environmental conditions.
- In normal conditions, whilst driving the **McHale 995 L+T**, the noise level to the driver's ear does not exceed 70 dB (A) with the rear screen of the tractor cabin open. The common noise level of the machine and the tractor is primarily influenced by the tractor noise (radio is an additional noise source). It is recommended to operate this machine with closed cabin windows.

4.4 Fire precautions

- Be aware that crops are easily inflammable.
- Do not smoke or make use of any open fire next to the machine.
- A functioning fire extinguisher should always be available on the tractor.
- The machine is to be kept clear of oil, grease, crops, string, plastic or any other flammable material at all times.
- Do not continue to work with overheated parts, cables or pipes, unless you have identified and eliminated the reason for overheating.

McHale 995 L+T Square Bale Wrapper



Keep hands out of the trap area
(CST00026)



Keep clear of rotating table
(CST00028)



Max table speed 30 R.P.M.
(CST00031)



Lift machine at these points
(CST00032)



Diagram of plastic film path through the dispenser
(CST00049)

McHale 995 L+T Square Bale Wrapper



Do not dismantle, risk of high pressure
(CST00056)



Read instruction manual
(CST00057)



Support table before working under it. Refer to the
instruction manual.
(CST00059)



Manual control valve, manual controls
(CST00064)

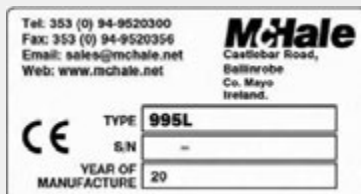

995 L series chassis plate

4.7 Machine lifting guidelines



WARNING: Machine Lifting

- Only use chains or strapping that are rated for a minimum load of 0.75 tonnes (750 kg) per chain or strap when using the four lift eye locations on the chassis, shown below
- The crane or lifting device must be capable of lifting a minimum load of 2.0 tonnes (2,000 kg)
- Never go under a suspended machine or attempt to try and stop it if moving erratically, death or serious injury may result
- Always be observant of people and objects around the suspended machine and do not allow the machine to impact heavily on the ground after suspension or movement



RHS front lift hook

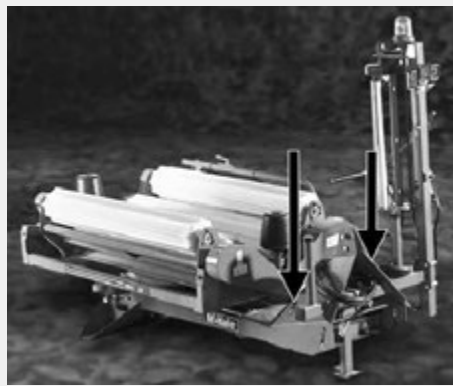

Front Lifting Points



LHS front lift hook



RHS rear lift hook

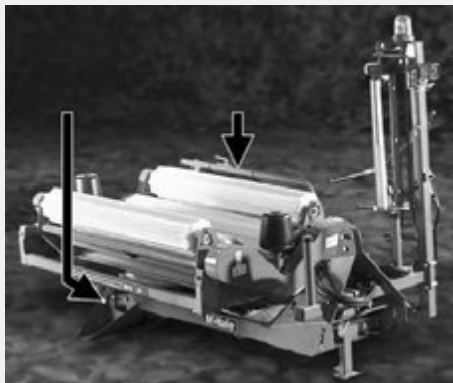

Rear Lifting Points



LHS rear lift hook

5

Tractor Requirements & Preparation

5.1 Tractor/power pack requirements

The minimum recommended size of tractor for operating the **McHale 995 L+T** comfortably on flat ground would be approximately 45 kw or for a power pack 10 kw. On hilly ground or difficult conditions, an additional 10 to 15 kw is advisable. The main requirement is that the tractor needs to be large enough to lift the machine safely.



NOTE: Use good quality oil

Ensure that the tractor has clean, good quality oil, hydraulic/universal oil to avoid problems later on. Also, the hydraulic filters on the tractor should be changed regularly, according to the manufacturer's service instructions. Avoid dirt getting into the hydraulic couplings.

The following items on the tractor are required for attachment of the bale wrapper to the tractor.

1. Category 2, three point linkage, tractor only (995 L) or Pin hitch with pin as supplied with tractor accessories (995 T)
2. Two 1/2" female quick releases for hydraulic power supply. The return line must be a freeflow to the tank (check with a **McHale** dealer for details).
3. One 12V electrical supply
4. One 7 pin lighting socket (995 T)

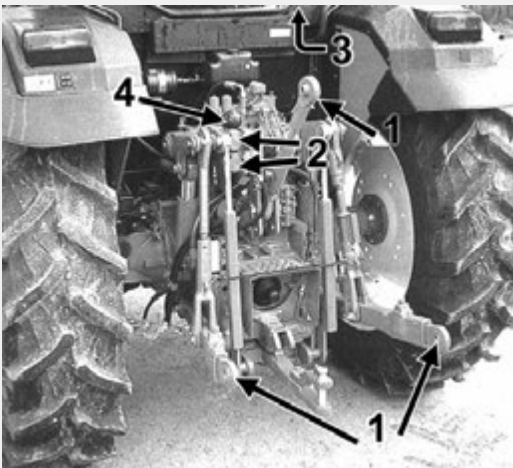

Figure 5.a - Tractor Requirements (995 L)

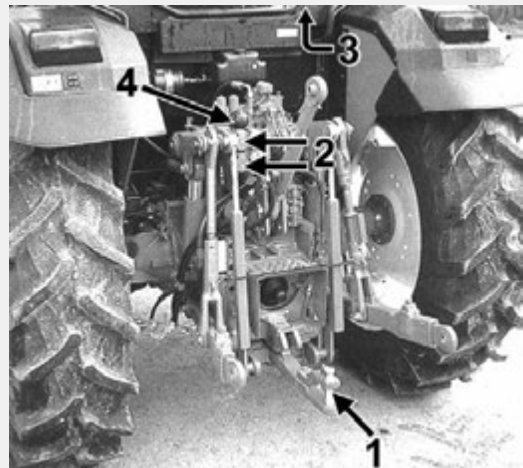

Figure 5.b - Tractor Requirements (995 T)

5.2 Hydraulic spool valve setup

The wrapper hydraulic valve must be set up in accordance with the type of hydraulic system on the tractor, that is being used. Check the tractor manual or with your dealer if you are unsure of which system is used on the tractor. If in any doubt after checking, use open centre settings as this will not damage the tractors hydraulics. The valve may be set up in two different ways:

1. Plug A (manual, part no CVA06003) (electronic, part no CVA06004)
This plug is used for both **open centre** and **load sensing** hydraulic systems. The hydraulic valve is set up to this specification when leaving the factory. When using load sensing hydraulics, always reduce the tractor oil flow to under 30 l/min.
2. Plug B (part no CVA06001)
This setting is used for **closed centre** hydraulic systems.

Changing from plug A to plug B (Manual & Electronic valves):

- (1) Remove plug A and replace with closed centre plug B
- (2) Tighten the relief valve fully

Changing from plug B to plug A (Manual & Electronic valves):

- (3) Remove the closed centre plug B and replace with plug A
- (4) Using a pressure gauge, set the relief valve to 160 bar

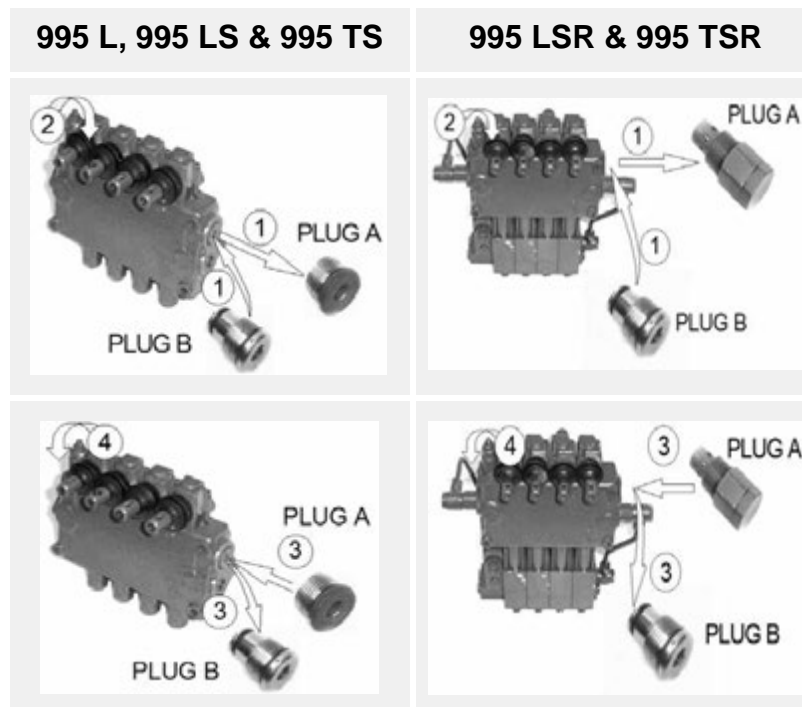

5.3 Attaching the wrapper (L Series)

1. Attach the lower link bar to the tractor lower links. Secure with linch pins provided (tractor only)
2. Reverse the tractor up to the wrapper, lining up the lower links of the tractor with the wrapper. Lift the hitch bar into the latch ensuring both sides have latched in properly (tractor only)
3. Attach the top link on the tractor to the top link holder on the wrapper (tractor only)
4. Plug the hydraulic feed hose into a suitable hydraulic spool valve. Ensure the control valve is correctly configured for the type of hydraulic system on the tractor. Refer to “Hydraulic spool valve setup” on page 24 for more details.
5. Plug the hydraulic return hose into a connection that has a freeflow into the back of the tractor/power pack. It is very important to ensure that it is in freeflow to get the best results from the wrapper.
6. Place the electronic box (995 LSR) or bale wrap computer (995 LS) in the tractor cab and secure it to the glass in an appropriate place, using the suction pad on the rear. The safety strap must be secured to protect the box from accidental damage. If there is no cab on the tractor secure as appropriate, bearing in mind the box is not waterproof. If using a power pack attach it in a suitable position where it cannot be damaged.
7. Screw the 37 pin socket on the electronic box and the 37 pin plug on the machine together (995 LSR). Connect the control box to the trailer socket or battery, using the power cable provided. There must be a good 12 V supply to the control box.
8. Connect the bale wrap computer (995 LS) to the trailer socket or direct to the battery, using the power cable. There must be a good 12 V supply to the bale wrap computer.



CAUTION: Control levers must be stored appropriately

For 995 L and 995 LS place the control levers in an appropriate place, either on the machine or on the tractor. Cable controls may be placed in the cab if desired. However manual spool valve controls must be kept outside the tractor cab.

9. Check that all of the above functions operate correctly.
10. The machine is now ready to work.

5.4 Attaching the wrapper (T Series)

1. Reverse the tractor up to the wrapper, lining up the tractor hitch with the wrapper hitch-eye. Fit the tow pin to the hitch ensuring it is secure, by inserting a linch pin.
2. Screw the jack up fully, off the ground.
3. Plug the 7 pin lighting plug into the 7 pin socket on the tractor.
4. Now follow the instructions from No. 4 in “Attaching the wrapper (T Series)” (Section 5.3)



Figure 5.c - Bale Wrap Computer



Figure 5.d - Electronic Control Box

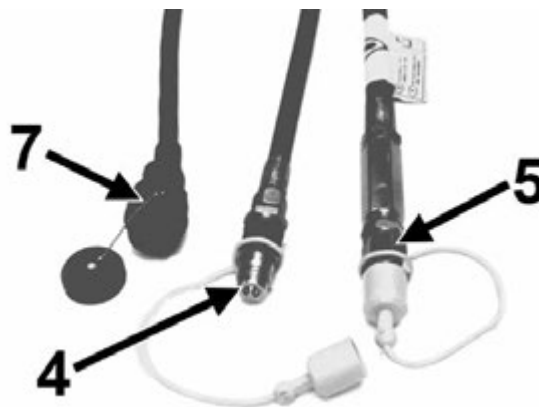

Figure 5.e - Hoses and cable

5.5 Connecting the control box

The control box is to be connected to a 12 V / 20 Amp power supply either using the supplied euro socket or the battery power cable. A good power supply is critical for proper machine operation as the electronic control box is the main interface between the operator and the machine.



CAUTION: Do not connect control box to a 24 V power supply

Do not attempt to connect control box to a 24 V power supply, as machine component damage will result.

6

Bale & Plastic Film Requirements

6.1 Bale Requirements

The bales to be wrapped should be well shaped, dense and of suitable quality for making silage. Substandard material will not produce good quality silage regardless of how well the bale is wrapped.

Square bales

- Cross section: 800-900 mm wide, 600-1,000 mm high
- Length: Up to 1,800 mm long

Round bales

- Bale width: Up to 1,500 mm wide
- Bale height: Diameter up to 1,500 mm high

The roller cradle centres must be set up correctly for the size of the bale being wrapped to ensure even coverage of plastic film on the bale. (To adjust the roller cradle centres, see "Table cradle drive chains" on page 64)

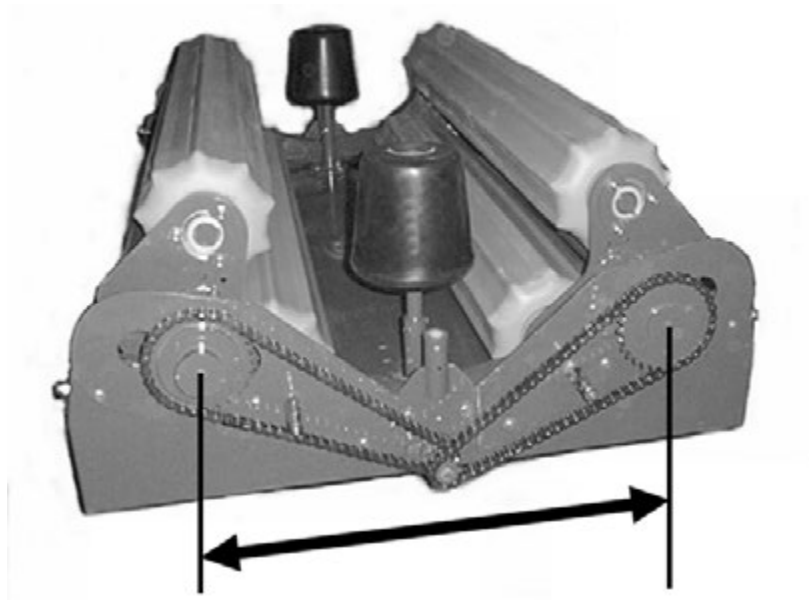

Figure 6.a - Roller cradle centres

McHale 995 L+T Square Bale Wrapper

There are 3 settings for the width between the roller cradle centres:

Cradle drive setting:	Typical Bale Size:
810 mm	600 x 900 mm, or where the shortest side of the bale is within a 600-650 mm range
850 mm	700 x 800 mm or where the shortest side of the bale is within a 650-750 mm range
900 mm	800 x 900 mm or where the shortest side of the bale is within a 750-800 mm range

6.2 Plastic Film Requirements

It is of the utmost importance that top quality plastic film is used for wrapping bales. Always follow plastic film manufacturer's recommendations on the storage and use of the film.

It is recommended that a minimum of 4 layers of film are applied to the bale. If the material being wrapped is of a hard or stemmy nature it may be necessary to apply 6 or 8 layers to ensure a good airtight package.

The operator needs to ensure that the bale is correctly wrapped. It is good practice to periodically check the bales after being wrapped for any torn, split or punctured plastic film. If the stubble in a particular field has a tendency to puncture the plastic film, it is strongly advised to wrap the bales at the stack, where there may be more control over ground conditions.

The plastic film must be applied to the centre of the bale. If it is too low or too high adjust the dispenser height as appropriate. See "Dispenser height" on page 58.

To determine the number of table rotations required to wrap a bale, carry out the following procedure:

1. Count the number of table revolutions to cover the bale completely with plastic film
2. Add 1 to this number
3. Multiply this resultant figure by 2 (for 4 film layers) or 3 (for 6 film layers)

Example:

- Number of rotations to cover the bale: 7
- Number of rotations to apply 4 layers of film to the bale: $(7+1) \times 2 = 16$



ENVIRONMENT: Recycling of film roll

Respect the environment! Never throw away or burn the waste film and the core tube. Always take waste materials to a recycling centre.

6.3 Care of the film roll

The film roll should be protected from damage and moisture and prolonged exposure to the sun. Do not remove the protective cover until ready for use. Film damage can cause undesired film performance and affect bale weatherability.

7

Manual Controls (995 L & LS)

The manual controls on the 995 L & LS consist of a four bank manually operated spool valve, operated directly by levers

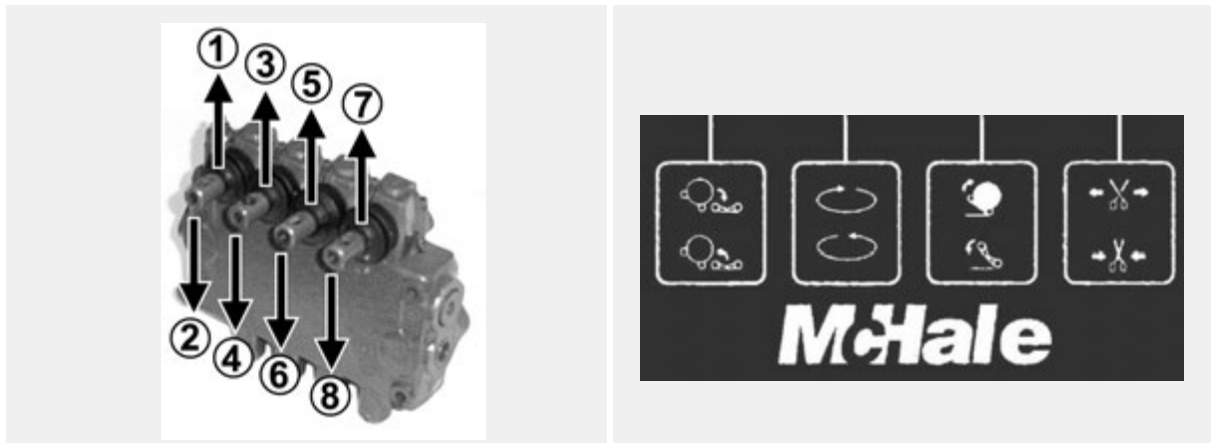

No.	Function	No.	Function
1	Lift arm up	2	Lift arm down
3	Table reverse	4	Table forward
5	Table tip	6	Table lower
7	Cut & hold open	8	Cut & hold close

8

Electronic Control System

8.1 Bale Wrap Computer (995 L & 995 LS)

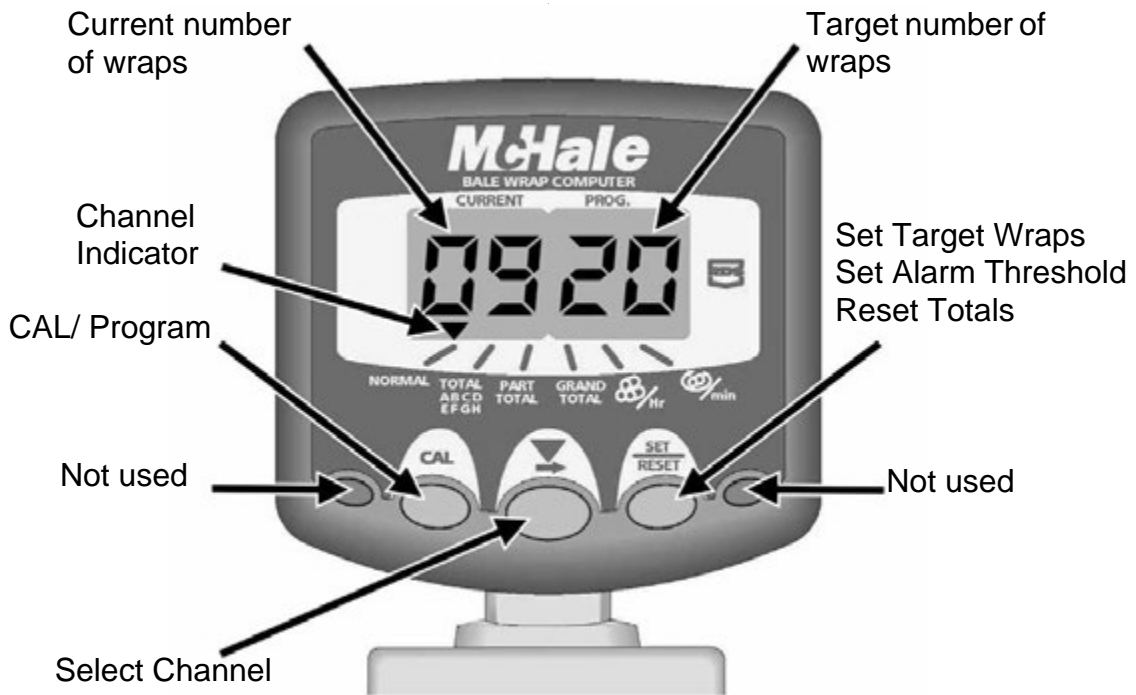

There are three buttons at the centre of the front panel:

- CAL or Program
- Select Channel
- Set or Reset

These are used individually or in combination to program, set/reset or select a function.

The Bale Wrap Computer is used to monitor and control a number of different **McHale** bale wrapping machines both manual and semi-automatic. It is very important that the correct program be selected to control the wrapping machine.

Model	Type of control	Program
995 L or 995 LS	Manual	Program 1

8.1.1 Selecting a Program

1. Unplug the Bale Wrap Computer to switch it off
2. Press and hold the “CAL” Button
3. Switch on the computer
4. Release the “CAL” Button
5. The display shows the over speed alarm setting
6. Press and release the “CAL” Button again
7. The last digit will flash “1”, “2” or “3”
8. Change by pressing “SET/RESET”
9. When the correct program number is displayed switch off the computer
10. The settings will be retained in the memory

8.1.2 Channels

The Bale Wrap Computer has six channels which are used to monitor the various operations of the machine.

Channel	Display	Description
1	NORMAL	“Normal” display (Current/Target no. of wraps)
2	TOTAL A B C D E F G H	Store Totals (A-H)
3	PART TOTAL	Part Total
4	GRAND TOTAL	Grand Total
5		Bale Wrapping Rate
6		Bale Wrapping Speed

8.1.3 Channel 1 - Current/Target Wraps Display



The left hand section shows the current number of wraps and the right hand section shows the target number of wraps.

When the current number = Target number, the alarm will sound for 2 seconds and the display will flash. (If set, the early warning alarm sounds beforehand).

Automatic reset of the current number to zero normally occurs 3 seconds after the target number is reached. If additional wraps are added after the target number is reached, the current number will continue to advance.

Manually reset the current number of wraps to zero



Press to select **NORMAL** Channel



Press and hold to reset

Program the target wraps



Press to select **NORMAL**



Hold continuously



The third digit flashes

McHale 995 L+T Square Bale Wrapper



Hold to cycle to the required digit then release, otherwise press once...



The fourth digit flashes



Hold to cycle to the required digit
Release all

Program Early Warning Alarm

An early warning alarm can be programmed to sound from 1 to 9 wraps before the target number is reached. Depending on the setting, the alarm will sound long beeps for up to 8 wraps, short beeps for the final wrap, and then a continuous beep for three seconds.

For example, if the bale requires 22 wraps and you want an alarm at 20 wraps, then set the number to 2.

To effectively disable the alarm, set the number to 0



Press to select 



Hold continuously



The fourth digit flashes



Hold to cycle to the required digit
Release all

8.1.4 Channel 2 - Store Totals (A-H)

When bale wrap is complete, one of eight pre-selected memory store totals A, B, C, D, E, F, G or H, is automatically advanced by 1. Store totals can be reset individually.

Display a Store Total



Press to select

TOTAL
ABCD
EFGH

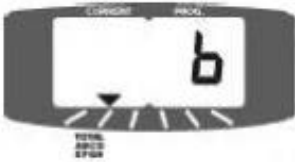

The fourth digit displays the current store designation for 2 seconds



The current total for that store then displays for 5 seconds, then defaults to Channel 1

Select a Store Total



Press to select

TOTAL
ABCD
EFGH



Select the desired store total (A-H)



This is now the default store, and subsequent bale counts are stored there until another store is selected

Reset a Store Total



Press to select

TOTAL
ABCD
EFGH



Select the desired store total (A-H)



Press and hold to reset

8.1.5 Channel 3 - Part Total

When the bale wrap is complete, the part total is automatically advanced by 1. The part total can be reset at any time.

Display Part Total



Press to select

PART
TOTAL



Part total displays for 5 seconds then defaults to channel 1

Reset Part Total



Press to select

PART
TOTAL



Press and hold to reset

8.1.6 Channel 4 - Grand Total

When the bale wrap is complete, the grand total is automatically advanced by 1. The grand total cannot be reset.

Display Grand Total



Press to select **GRAND TOTAL**



Grand total displays for 5 seconds then defaults to channel 1

8.1.7 Channel 5 - Bale Wrapping Rate

Displays the number of bales wrapped per hour. The time period over which the rate is average may be re-started at any time.

Display Bale Wrapping Rate



Press to select 



Reset Timing Period



8.1.8 Channel 6 - Bale Wrapping Speed

Displays instantaneous r.p.m. of the bale wrapper at 3 second intervals in the range 10-99 r.p.m. An overspeed alarm will sound if the r.p.m exceeds a pre-programmable limit. The display will default to this channel and flash for the duration of the overspeeding, subsequently reverting to the “current/target wraps” display.

Display Bale Wrapping Speed



8.1.9 Program the Overspeed Alarm



McHale 995 L+T Square Bale Wrapper



The third digit flashes



Hold to cycle to the desired digit, then release, otherwise press once...



The fourth digit flashes



Hold to cycle to the required digit.
Release all

8.1.10 Total Reset

If for some reason the date in the instrument is corrupted or the display shows “PrOg” then the instrument must be totally reset.

- Switch power off
- Press and hold all 3 control switches
- Switch power on
- Release all switches

All instrument settings should be returned to the factory-set values. If the display shows “PrOg” again, the instrument may be faulty and must be returned to the manufacturer for inspection and repair.

8.2 Electronic Control Box (995 LSR, TS & TSR)

The Electronic Control box is the main interface between the operator and the machine. While the machine is fully automatic mode, setting up is required before wrapping commences. It is also possible to work the machine manually through the buttons on the control box. The Electronic Control Box is fitted to the following machines:

- 995 LSR
- 995 TS
- 995 TSR

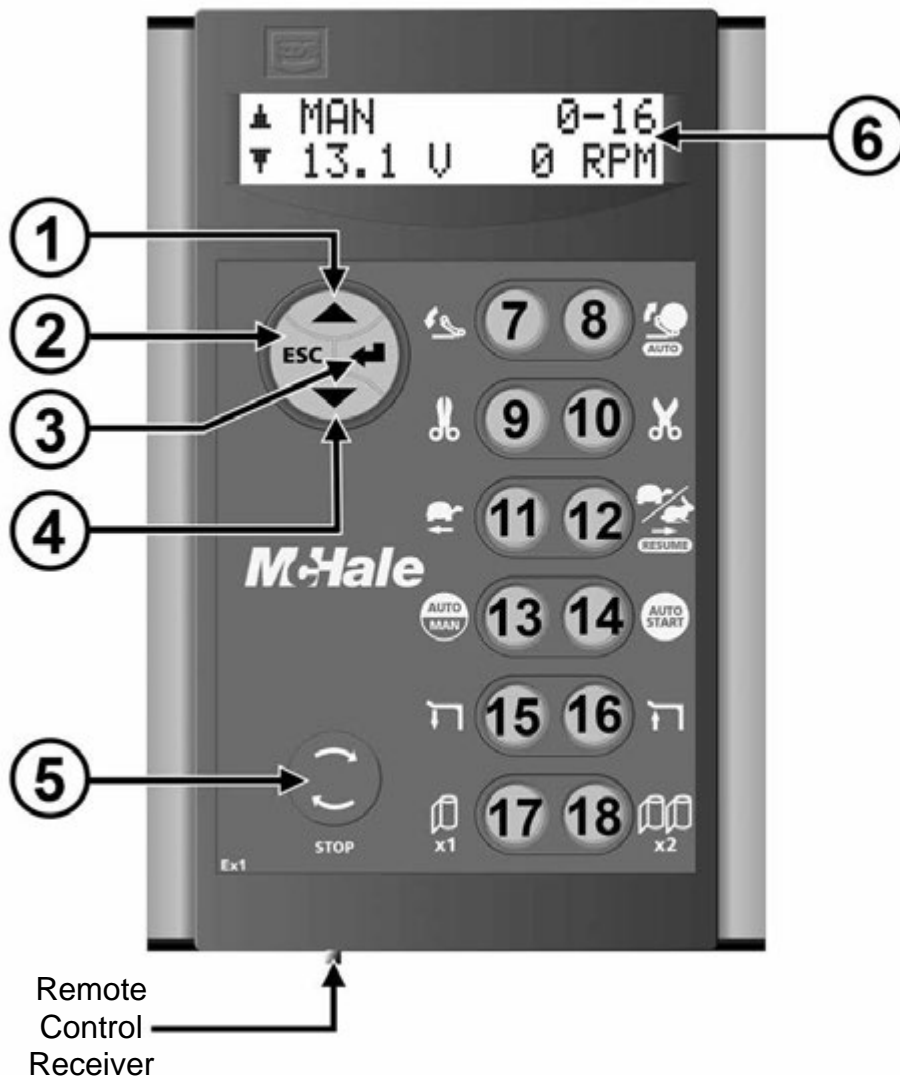

8.3 Electronic Control Box Functions

No.	Function
1	Display Up
2	ESC, i.e. return to the working screen
3	Enter
4	Display Down
5	Stop
6	Display Screen
7	Table tip (In Automatic Mode, it starts the tipping part of the cycle)
8	Table lower
9	Cut & hold close
10	Cut & hold open
11	Table reverse (slow)
12	Table forward (slow/fast) Press the button for slow speed, release & quickly press it again for fast Resume: Restarts the wrapping or any other interruption
13	Automatic/Manual mode
14	Automatic cycle start
15	Bale lift arm down
16	Bale lift arm up
17	Not used on this machine
18	Not used on this machine

8.4 Available wrapping programs

The following list shows the list of wrapping programs that are available. The items that are greyed out are not used/available on this machine.

Program		Description	Table start position
Standard	0	Not used on 995_L series	Cut & hold at left side of the machine
Combi trailed	00	Not used on 995_L series	
Combi standard	IL	Not used on 995_L series	
Remote	R97L	Not used on 995_L series	Cut & hold at the left side of the machine
Remote	R94	995 LSR standard	Cut & hold at the front of the machine
Remote	RT	Not used on 995_L series	Cut & hold at the front of the machine
Remote	R	Not used on 995_L series	
Side load	SR94	995 LSR side load	Cut & hold at the left side of the machine

8.5 Electronic Control Box Setup

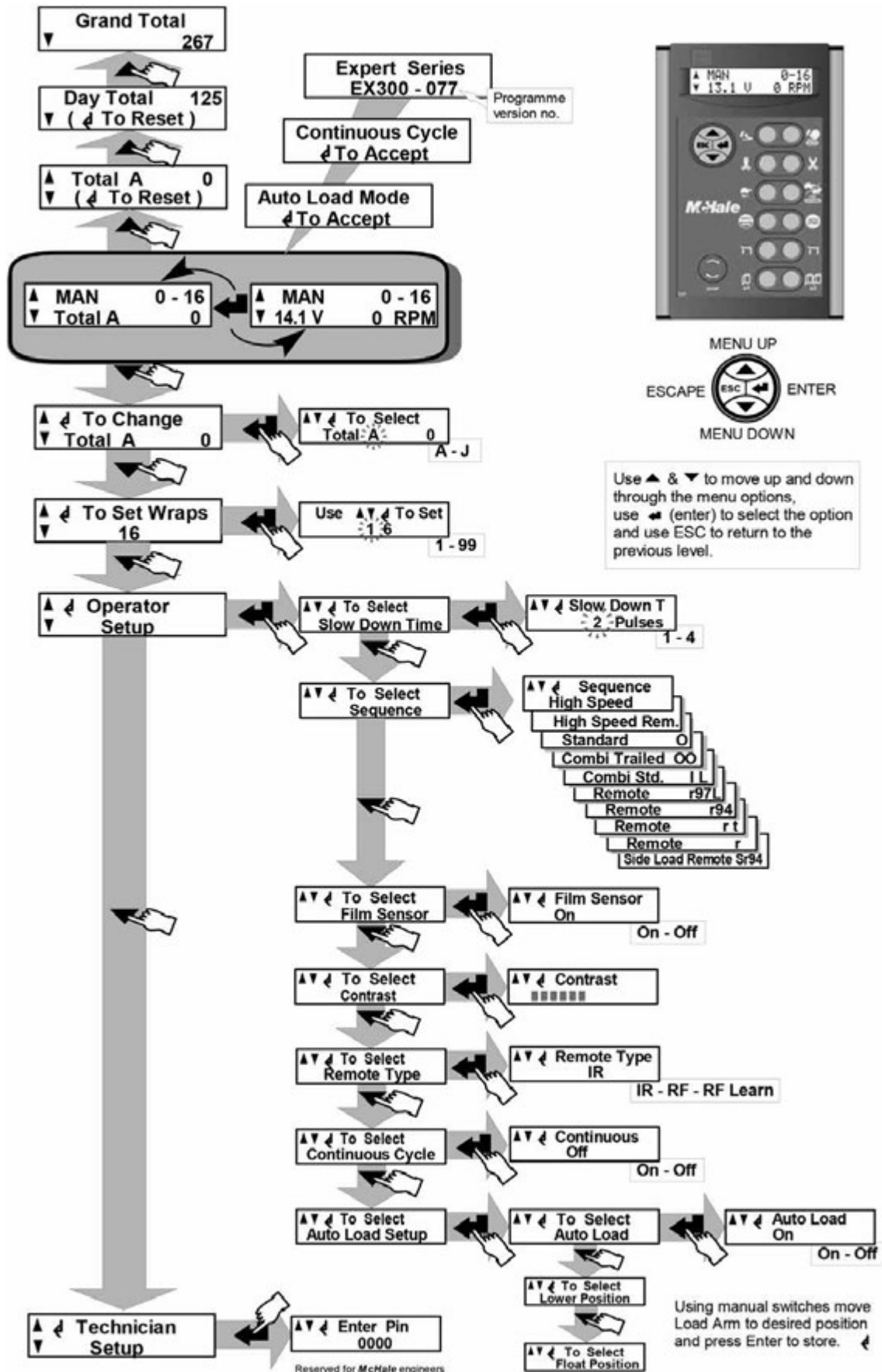

8.6 Electronic Control Box Features

8.6.1 Working Display

When the Electronic Control Box is first switched on it displays “Expert Series”, with the software version number beneath.



NOTE: Continuous Cycle and Auto Load sequence “ON” settings must be confirmed every time

Every time the Electronic Control Box is turned on Enter (Button 3) must be pressed to confirm the Continuous Cycle (See “Continuous Cycle” on page 50) and Auto Load Setup (See “Auto Load Setup” on page 50), if these were previously set to on. If you don’t press Enter for each sequence, it will default the setting to OFF!

After a short delay the working display (Screen 1 of 2) appears. Press Enter (Button 3) to toggle between the two screens. The working display contains two lines:

1. The upper line displays the machine status i.e. manual or automatic, the current wrap count and the target number of wraps. The upper line remains constant in both Screens 1 & 2. (See Figures 8.a and 8.b)
2. The lower line of Screen 1 displays the voltage and the table speed in RPM and the lower line of Screen 2 displays the current bale counter and its counter total.

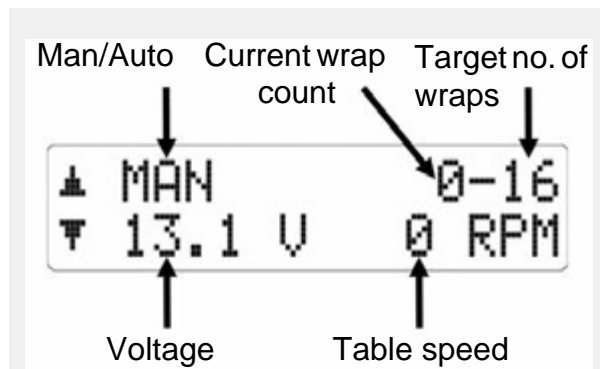

Figure 8.a - Working display (Screen 1)

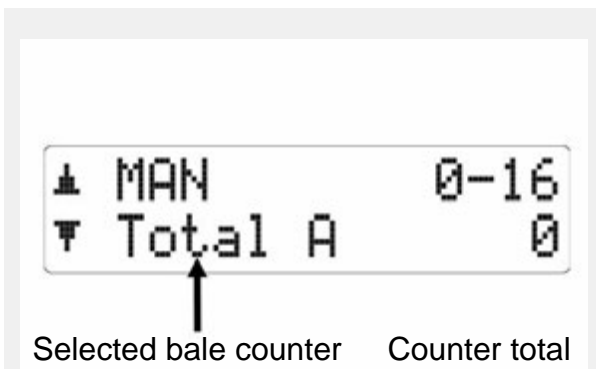

Figure 8.b - Working display (Screen 2)

8.6.2 Counters

The Expert Series Electronic Control Box contains the following counters:

- **Ten different bale counters (A - J)**, which can be reset. These bale counters can be used to measure the amount of bales wrapped for various customers by using a different counter for each customer.
- **Day Counter**, which can be reset. Every bale wrapped by the machine is added to the day total count regardless of the customer counter that is currently selected. It can be reset at the start/end of every day.
- **Grand Total Counter**, which cannot be reset. Every bale that is wrapped by the machine is added to this counter.

Select & set a Bale Counter (A-J)

1. From the working display, press the Display Down (Button 4) once to select To Change Total
2. Press Enter (Button 3) to move to the To Select Total "X" display
3. Select desired counter (A -J) using the Up and Down Arrows (Buttons 1 & 4)
4. When you reach your desired counter press Enter (Button 3) to select it
5. Press the Up Arrow (Button 1) or ESC (Button 2) once to return to the working display

Reset the Current Bale Counter (A-J)

1. Press the Up Arrow (Button 1) once, from the working screen
2. The current bale counter total will be displayed
3. Press Enter (Button 3) to reset it
4. Press the Down Arrow (Button 4) or ESC (Button 2) once to return to the working display

View the Day Total Bale Counter

1. Press the Up Arrow (Button 1) twice, from the working screen
2. The day total counter will be displayed
3. Press the Down Arrow (Button 4) or ESC (Button 2) twice to return to the working display

Reset the Day Total Bale Counter

1. Press the Up Arrow (Button 1) twice, from the working screen
2. The day total counter will be displayed
3. Press Enter (Button 3) to reset it
4. Press the Down Arrow (Button 4) or ESC (Button 2) twice to return to the working display

View the Grand Total Bale Counter

1. To view the grand total bale counter, press the Up Arrow (Button 1) three times, from the working screen
2. The grand total counter will be displayed
3. Press the Down Arrow (Button 4) or ESC (Button 2) three times

8.6.3 Voltage Monitor

The "Expert Series" Electronic Control Box monitors its operating voltage and displays it during wrapping. If the voltage falls below a safe level "LOW BATT" is flashed on the display. The usual causes of low voltage are:

- A bad battery
- A defective charging circuit
- Loose or corroded connections
- Fuses or a faulty power lead to the control box

8.6.4 To Set Wraps

To change the desired/target number of film wraps:

1. Press the Down Arrow (Button 4) twice, from the working screen, to display the To Set Wraps Screen
2. Press Enter (Button 3) to move to the Use To Set Screen
3. Use the Up and Down Arrows (Buttons 1 & 4) to make changes to the first flashing digit and when the desired figure is displayed, press Enter (Button 3). The second digit is programmed in a similar manner. When the target number of wraps is displayed, return to the working display by pressing ESC (Button 2) or the Up Arrow (Button 1) twice.

8.6.5 Operator Setup

To enter the Operator Setup Menu:

1. Press the Down Arrow (Button 4) three times from the working screen
2. Press Enter (Button 3) to move to the Operator Setup options:
 - Slow Down Time
 - Wrapping Sequence/Program
 - Film Sensor
 - Display Contrast
 - Remote type
 - Continuous Cycle
 - Auto Load Set up
3. Use the Up and Down Arrows (Buttons 1 & 4) to select an item, press Enter (Button 3) to adjust the current selection/setting.

Slow Down Time

This setting determines when the table goes into slow down speed at the end of a wrapping cycle. The adjustment range is from 1 to 4 sensor pulses. (There are 2 sensor pulses per table revolution). To change the slow down time:

1. Press the Down Arrow (Button 4) three times
2. Press Enter (Button 3) once to move to the Select Slow Down Time Screen & press Enter again to adjust the setting
3. Use the Up and Down Arrows (Buttons 1 & 4) to change the value, press Enter (Button 3) to save the new setting.

Wrapping Sequence/Program



CAUTION: Select the correct wrapping sequence before using the machine

The "Expert Series" Electronic Control Box is designed to control a number of different **McHale** wrapping machines, therefore, it is very important that the correct wrapping sequence be selected to suit the machine in use, before work begins.

McHale 995 L+T Square Bale Wrapper

It is crucial that the correct wrapping sequence/program is selected for the **995 L+T**. Please refer to “Available wrapping programs” on page 42 to see which sequence/program applies to this machine.

To change the wrapping sequence/program:

1. Press the Down Arrow (Button 4) three times
2. Press Enter (Button 3) once
3. Press the Down Arrow once and press Enter again
4. Use the Up and Down Arrows (Buttons 1 & 4) to select a sequence, press Enter (Button 3) to save a new sequence/program.

Film Sensor

The film sensor monitors the passage of film through the dispenser rollers. If the roll empties or the film breaks, “FILM BREAK” will be flashed on the display and the wrapping table will rotate forward in slow speed and pause briefly. The table then rotates slowly in reverse to a position before the film breakage and waits for the film to be replaced. The operator must apply the parking brake, switch off the tractor and remove the key before replacing the film roll and attaching the film to the bale. When the tractor is restarted, press “Resume” (Button 12) to complete the wrapping.

Film sensors are normally turned “On”, but can be switched “Off” from the Operator Setup Menu, if film sensing is not desired or if there is a problem with a sensor. To set the sensor On/Off:

1. Press the Down Arrow (Button 4) three times
2. Press Enter (Button 3) once
3. Press the Down Arrow twice to move to the Select Film Sensor Screen and press Enter
4. Use the Up and Down Arrows (Buttons 1 & 4) to adjust the setting i.e. On/Off
5. Press Enter (Button 3) to save the new setting

If the operator wants to continuously operate the machine with only 1 single roll of film, they should select the “1 roll of film” mode, by pressing Button 16 and holding it for 3 seconds. A short beep will sound and “1 roll film” will be displayed on the screen. This mode doubles the target count and reduces the bale indexing speed to half, so that the machine can be operated the same as a standard single dispenser 991 BE machine. The film must then be loaded onto the lower dispenser unit only (See “Loading plastic film” on page 53) and the dispenser height must be set to its highest position (See “Dispenser height” on page 58).

To go back to normal twin dispenser operation, Button 17 must be held pressed for 3 seconds until “2 rolls film” is displayed on the screen. The dispenser height must be returned to its lowest position (See “Dispenser height” on page 58).

Display Contrast

Extremes of temperature may affect the contrast of the display which is adjustable from the contrast menu. To adjust the contrast:

1. Press the Down Arrow (Button 4) three times
2. Press Enter (Button 3)
3. Press the Down Arrow (Button 4) three times and press Enter
4. Use the Up and Down Arrows (Buttons 1 & 4) to adjust the setting
5. Press Enter (Button 3) to save the new setting

Remote Type

This option is used to select the remote control type. There are 2 different types used:

- Infrared (IR) - Older machines
- Radio frequency type (RF) - Newer machines

To select the remote type:

1. Press the Down Arrow (Button 4) three times, to select the Operator Setup Menu
2. Press Enter (Button 3)
3. Press the Down Arrow (Button 4) four times and press Enter
4. Select either IR/RF/RF Learn, as appropriate
5. Press Enter (Button 3) to save the selection

Infrared Remote

Whenever an Infrared remote type is being used, select "IR" in the Remote Type Menu, as above. Connect the receiver to the serial port on the Electronic Control Box and select Auto mode (Button 13). The cycle can be started by pointing the infrared remote at the receiver and pressing the Auto Start Button (See Figure 8.d). The Emergency Stop Button will stop the cycle at any time. The other two buttons will rotate the table in forward and reverse.



Figure 8.c - Infrared Receiver

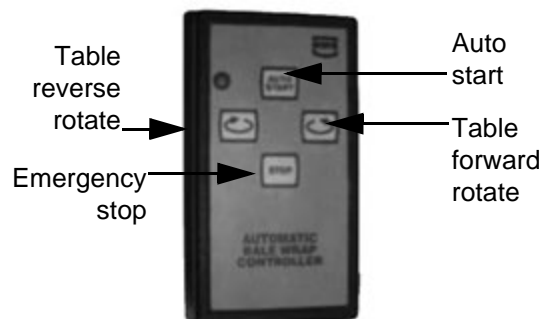

Figure 8.d - Infrared Remote

McHale 995 L+T Square Bale Wrapper

Radio Remote

Whenever a radio remote is being used for the first time, the remote frequency code must be “learned” by the Electronic Control Box. Select “RF LEARN” in the Remote Type Menu and connect the receiver to the serial port on the Electronic Control Box and select Auto mode (Button 13). Press the Stop Button on the radio remote (See Figure 8.f). A code will appear on the screen of the Electronic Control Box to show that the radio frequency code has been stored. ESC (Button 2) can then be pressed to return to the working screen and the remote is ready to use.

This procedure only needs to be followed when the remote handpiece is used with an Electronic Control box for the first time. The “RF” type will be automatically used once the remote frequency code has been established. Up to 7 handpieces can be programmed into the one Electronic Control Box, if desired. Each remote handpiece has a different code which ensures that multiple wrappers can operate in the same location, without interfering with each other.



CAUTION: Press the safety button on the radio remote simultaneously with all function buttons, except for Stop

There is a safety button located on the back of the remote which needs to be pressed simultaneously with each function button to activate it. This safety button doesn't need to be used for the Stop Button.



WARNING: Radio remotes have a very long range, do not accidentally press any buttons when not near the machine

There is a very long range with radio remotes (approx. 200 metres in the line of sight), so care must be taken not to accidentally press any buttons even when not near the machine. The control box must be in AUTO mode before any remote functions will work.

With either remote type, pressing the “Table Forward Rotate” Button on the handpiece during wrapping will switch On/Off a 12 volt output on one of the spare electrical connectors on the wrapper wiring loom. This feature can be used to switch on an external valve on a hydraulic power pack to select a lower oil flow setting (This is useful when wrapping badly shaped bales).

There is a spare connector on the wrapper wiring loom marked with the letter “E”. (On machines up to serial no. 58297 the white/blue wire is +12 volts and the yellow/green is ground). (On machines from serial no. 58298 the brown wire is +12 volts and the yellow/green is ground).

The maximum current available on this 12 volt output is 3 amps.

McHale 995 L+T Square Bale Wrapper



Figure 8.e - Radio Receiver

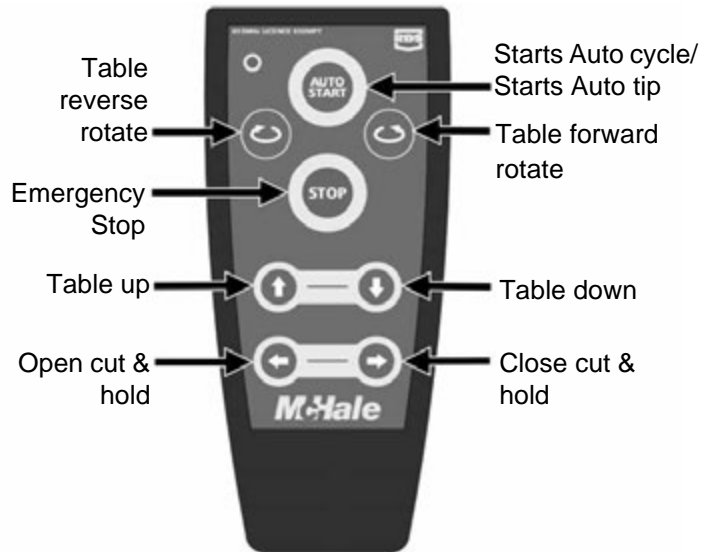

Figure 8.f - Radio Remote

Continuous Cycle

The Continuous Cycle, when enabled, allows the wrapping machine to complete the wrapping cycle without waiting for the operator to press Table Tip (Button 7) to start the tipping part of the cycle. Every time the Electronic Control Box is switched on, it asks the operator to press Enter (Button 3) to confirm that the Continuous Cycle is required.



CAUTION: Do not use the continuous cycle on hilly terrain

The continuous cycle should not be used in hilly terrain as the operator needs better control of bale unloading i.e. the bale should be unloaded on level ground.

To turn the continuous cycle On/Off:

1. Press the Down Arrow (Button 4) three times, to select the Operator Setup Menu
2. Press Enter (Button 3)
3. Press the Down Arrow (Button 4) five times and press Enter
4. Use the Up and Down Arrows (Buttons 1 & 4) to select On/Off
5. Press Enter (Button 3) to save the new setting

Auto Load Setup

The Auto Load feature, when selected, enables automatic loading of the bale. The loading arm normally sits at the preset float position. On approaching the bale, "Auto Start" (Button 14) is pressed, the loading arm drops to the preset lower position and the machine is moved forward to receive the bale. "Auto Start" is pressed again; the loading arm lifts the bale onto the wrapping table, the arm lowers to the float position and wrapping starts. Both the float position and the lower position may be adjusted. To set the Lower/Float Position:

1. Press the Down Arrow (Button 4) three times, to select the Operator Setup Menu
2. Press Enter (Button 3)

McHale 995 L+T Square Bale Wrapper

3. Press the Down Arrow six times
4. Press Enter to move to the Select Auto Load Screen
5. Press the Down Arrow (Button 4) once to select the Lower Position or twice to select the Float Position
6. Using the Bale lift arm down (Button 15) and Bale lift arm up (Button 16), move the arm to the desired position (Lower/Float). When it is correct, press Enter (Button 3) to store the setting for the current position and press the Up Arrow (Button 1) to return to the Select Auto Load Screen
7. When both settings are correct, press Enter to move to the Auto Load Screen and change the setting to ON.

More accurate settings can be achieved if the adjustments are done as the arm is moved from a higher to a lower position. Every time the Electronic Control Box is switched on the operator must press Enter (Button 3) to confirm that the Auto Load Cycle is required.

8.6.6 Technician Menu

The technician menu is reserved for **McHale** engineers only. A pin code needs to be entered to access the menu.

9

Wrapper Operation



WARNING: Keep out of the “Danger Zone”

Keep all persons outside of the “Danger Zone” during all machine operations! See “Danger Zone” on page 13.



ENVIRONMENT: Recycling of the plastic film

Respect the environment! Never dump or burn waste plastic film. It's toxic! Always take waste materials to a recycling centre.

9.1 Preparing the machine for wrapping

1. Load the plastic film into the dispenser running it through the rollers as shown in Figure 9.b. Attach the film to the bale. See “Loading plastic film” on page 53.
2. Turn on the oil supply
3. Switch on the electronic control box and set to “Automatic” mode (Electronic models).
4. Connect the bale wrap computer (Manual control models)
5. Ensure the table is in the correct starting position (see “Table load position magnet (SR94 Program - 995 LSR & TSR)” on page 59). On electronic machines, the control box needs to be set on “manual” to work this function.
6. The machine is now ready to wrap

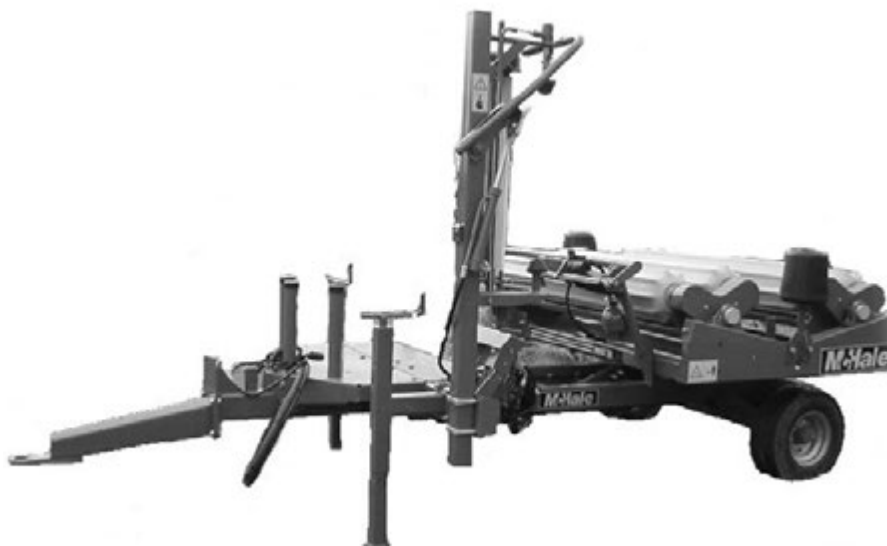

Figure 9.a - 995 T Machine

9.2 Loading plastic film

1. Push back the handle until the dispenser latches open.
2. When removing an old roll, push upwards to latch the top roll holder in the “up” position. Then remove the old roll core and dispose of it responsibly.
3. Sit the new roll onto the bottom roll holder and align it with the top roll holder.
4. While still the holding roll, pull the cable to release the top roll holder. The roll of plastic film is now held in position.
5. Thread the film through the dispenser rollers, as per the threading diagram (Figure 9.c)
6. Tie the end of the plastic film to the bale on the table. Never attempt to clamp plastic film in the cut & hold mechanism.
7. Close the dispenser by releasing the latch. The roll should now rest against one of the aluminium rollers.

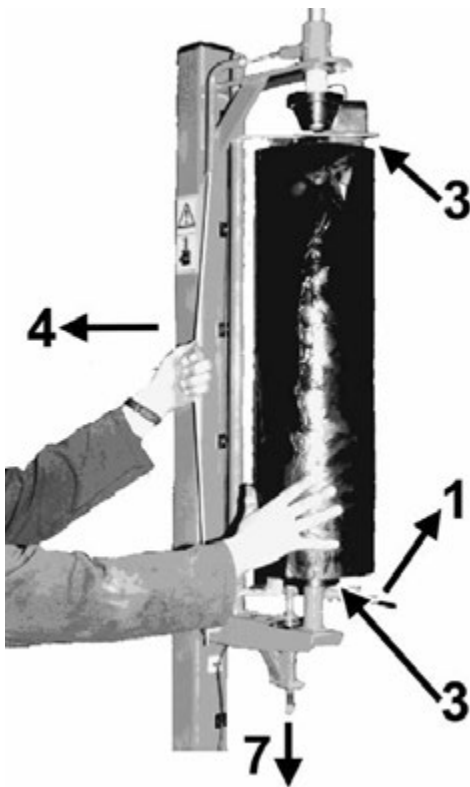

Figure 9.b - Loading plastic film

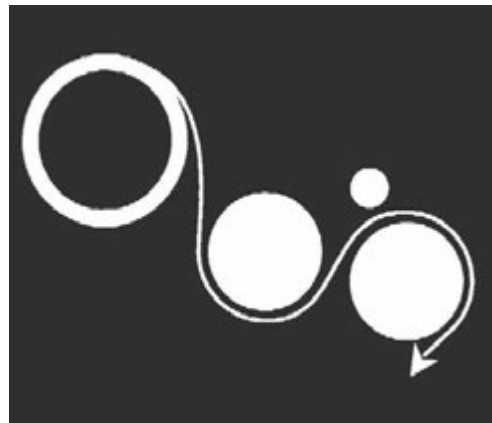

Figure 9.c - Plastic film threading diagram

9.3 Wrapping at the stack with remote control

The following is the recommended method for working the 995 wrapper as a static machine at the stack, using a remote control. It assumes the bales are well shaped for wrapping. However since it is impossible to allow for all differing conditions and terrain it may be necessary for the operator to vary this.

McHale 995 L+T Square Bale Wrapper



WARNING: Keep out of the “Danger Zone”

Keep all persons outside of the “Danger Zone” during all machine operations! See “Danger Zone” on page 13.

The electronic control box (if fitted) should be set to program “R94”. If side loading is desired use program “SR94”. The table must be in the correct starting position. Refer to “Electronic Control Box Functions” on page 41 for more details.

1. Park the machine on level ground with access for the loader, as required. Ensure the machine cannot move.
2. Load the bale onto the wrapper table using a **McHale** square bale handler.
3. The wrapper should now go through a sequence either worked manually or automatically, on electronic machines.
 - (a) Press “Auto start” on the remote control unit (995 LSR) or use manual hydraulic controls (995 L / 995 LS)
 - (b) The table starts rotating and plastic film is applied to the bale
 - (c) After a few revolutions the cut & hold releases the plastic film
 - (d) The table slows down two revolutions before the required number of revolutions is reached (995 LSR)
 - (e) The table stops rotating when the required number of rotations is reached. It is now lined up for tipping off.
 - (f) To tip the bale off, “auto start” must be pressed again (995 LSR)
 - (g) The table tips half way
 - (h) The cut and hold closes, holding and cutting the plastic film
 - (i) The table tips up fully and the bale rolls to the ground
4. The wrapper is now ready to receive another bale.



WARNING: Ensure the area is clear before operating the wrapper

Always ensure there is no person or wrapped bales in the way of the wrapper before operating it again.



WARNING: Turn off power before changing plastic film rolls

Always turn off the power source and the electronic control box, before changing the plastic film roll.

10

Road Traffic Safety & Operation

10.1 Before travelling on any public roadway



WARNING: Complete a full inspection before travelling on the road

Ensure that a full inspection is completed every time before attempting to go on to a public roadway, always think and practice safety!



NOTE: Check lighting system before travelling on the road

Before travelling on a public road, the operator must ensure that the complete (tractor and machine i.e. 995 T) lighting system is in a fully functioning condition.

The following must be checked, as a minimum requirement, before moving the machine on a public road.

1. The hydraulic supply must be turned off and protected from accidental activation by disconnecting the hydraulic feed line. Support all loose lines in a safe manner.
2. Ensure the lights (995 T) are connected and working correctly. Ensure that the wrapper (995 L series) does not obscure the tractor lights. If necessary, mount alternative lights.
3. Ensure the electronic control box or bale wrap computer is switched off.
4. If plastic film is to be transported on the machine it must only be done so on the holders provided and secured, if necessary. If plastic film is left in the dispenser during transport, ensure the aluminium rollers are pushed away from the roll of plastic, by having the spring latch in the up position.
5. Always transport the machine with the table at the narrowest position, i.e. in line with the chassis of the machine.
6. The operator must ensure that any other regulations regarding road use are strictly adhered to.

The following should be inspected every time, before travelling on a public road:

- Ensure that the tyres (995 T) are set to the correct pressure according to the specifications as outlined on “General dimensions & specifications” on page 10.
- Attention must be paid to the maximum travel speed-limit (40 km/hr) printed on the chassis plate (995 T), on the left hand side of the machine. Other

McHale 995 L+T Square Bale Wrapper

speed limits that may be printed, on the drawbar plate or axle plate, for example are not relevant.

- Ensure that all the national road traffic regulations relating to the country are fulfilled i.e. the use of safety chains may be mandatory in certain countries.

11

Field Operation & Wrapper Adjustments

From time to time it may become necessary to carry out adjustments to the machine, whether to improve machine performance or allow for general wear and tear. Such adjustments are part of the machine design. The following chapter gives details of how to go through the various adjustments. Some of these are field adjustments while others will be performed during machine maintenance or initial set-up. All of these adjustments should be checked thoroughly before the machine goes to work for the first time.

11.1 Drawbar height

The height of the drawbar may be adjusted to allow for the use of different tractors. The wrapper should be parallel to the ground when working. To change the height go through the following procedure:

1. Ensure the machine is securely chocked and supported
2. Remove the 3 x M16 nyloc nuts and the 3 x M16 bolts attaching the drawbar
3. Move the hitch to the new location
4. Insert the 3 x M16 bolts and tighten the nyloc nuts
5. Remove the support and chocks

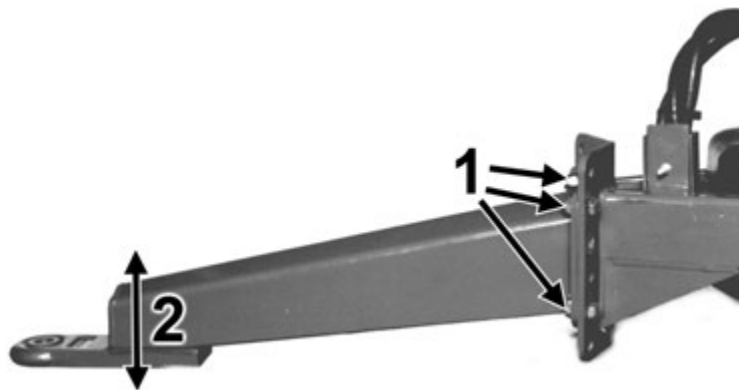

Figure 11.a - Drawbar height adjustment

11.2 Dispenser height

The plastic film needs to be applied around the centre of the bale, to ensure optimum coverage. The dispenser may need to be adjusted up or down, as necessary.

1. Ensure the machine is securely chocked and the dispenser is well supported
2. Loosen the 4 x M16 nyloc nuts on the U-bolts, but do not remove!
3. Slide the dispenser up or down, as required
4. Tighten the 4 x M16 nyloc nuts
5. Remove the support and chocks



Figure 11.b - Dispenser height adjustment

11.3 Table stop position magnet (Program R94 load position - 995 LSR & TSR)

If the table does not stop in the correct position in line with the chassis, it is possible to move the magnet that controls the stop position. However, it must be checked first that the machine is operating at the correct speed, has a bale on the table and the plastic film is attached, as all of these factors will have a bearing on where the machine stops (See Section 15.1.1 in “Trouble Shooting” on page 73).

The magnet may be adjusted as follows:

1. Tip up the table and fit the safety bar
2. Identify the magnet to be changed. There are two sets of magnets near the outside of the table. The magnets that require adjusting are positioned at the table end.
3. Loosen the M6 bolt and nyloc nut holding the magnets in position
4. If the table does not turn far enough, push the magnets in the direction shown
5. If the table turns too far, push the magnets in the direction shown
6. Tighten the M6 bolt and nyloc nut (Do not overtighten as the magnets may crack or shatter)
7. Remove the table safety bar and lower the table back down
8. Test the machine in automatic mode to see if it is stopping correctly, if not re-adjust

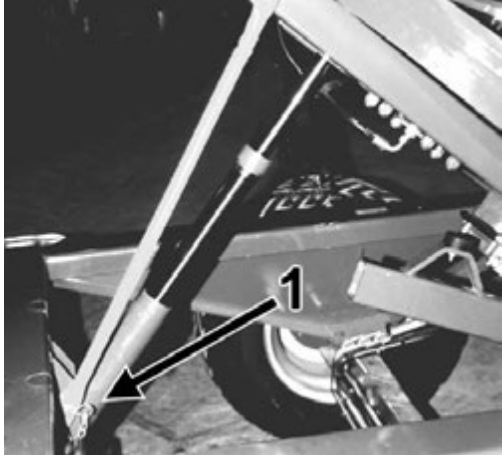

Figure 11.c - Tip up table & fit safety bar

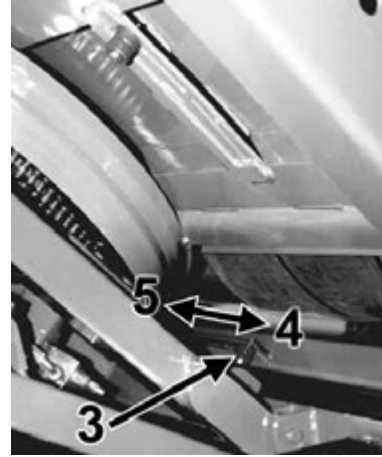

Figure 11.d - Table stop position magnet

11.4 Table load position magnet (SR94 Program - 995 LSR & TSR)

If the table does not start in the correct position, in line with the chassis and with the cut & hold to the left, it is possible to move the magnet that controls the start position.

Firstly, however, this must be checked with the machine operating at the correct speed, having a bale on the table with plastic film attached, as all of these factors will have a bearing on where the machine stops (See Section 15.1.1 in “Trouble Shooting” on page 73).

The magnet may be adjusted as follows:

1. Tip up the table and fit the safety bar
2. Identify the magnet to be changed. There are two set of magnets near the outside of the table. The magnets that require adjusting are positioned on the opposite side of the table to the cut & hold.
3. Loosen the M6 bolt and nyloc nut holding the magnets in position and move as follows
4. If the table does not turn far enough, push the magnets in the direction shown
5. If the table is turning too far, push the magnets in the direction shown
6. Tighten the M6 bolt and nyloc nut (Do not overtighten as the magnets may crack or shatter)
7. Remove the table safety bar and lower the table back down
8. Test the machine in automatic mode to see if it is working correctly, if not readjust

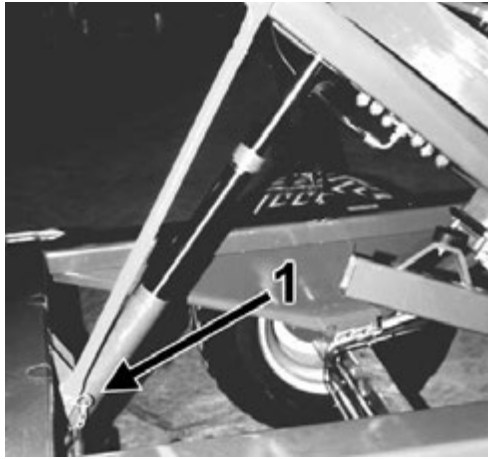

Figure 11.e - Tip up table & fit safety bar



Figure 11.f - Table load position magnet

11.5 Table half tip magnet (995 LSR & TSR)

The table half tip magnet does not normally require adjustment. However, as it is used as for the half tip position on electronic machines, it may need to be re-set. This will also affect the cut & hold operation.

1. Tip up the table and fit the safety bar
2. Loosen the M6 nut on the magnet
3. Move the magnet upwards to sense when the table is nearer the chassis, i.e. Table lowers more before indexing
4. Move the magnet downwards to sense when the table is further away from the chassis, i.e. Table lowers less before indexing. Do not push down too far, as the table may hit the bale damper while indexing.
5. Tighten the M6 nut
6. Remove the table safety bar and lower the table back down. Test the machine and re-adjust, if necessary.

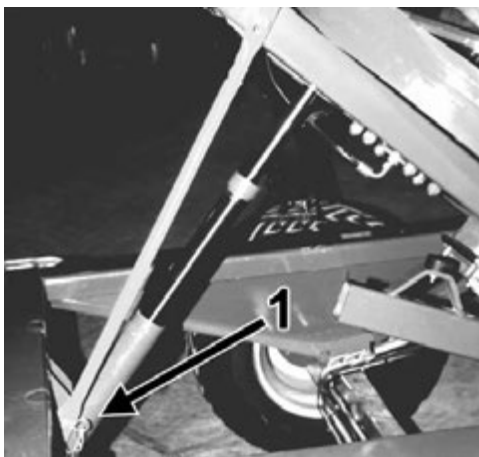

Figure 11.g - Tip up table & fit safety bar

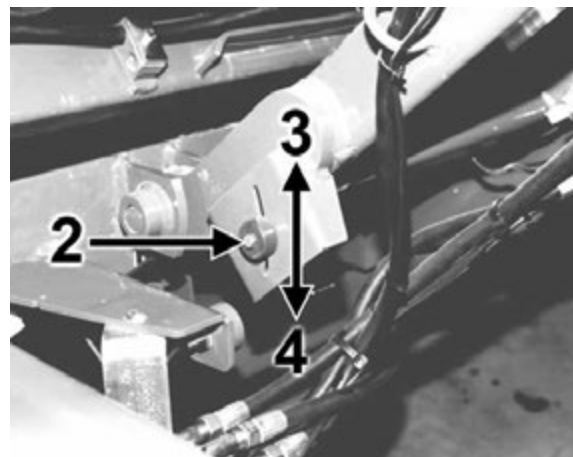

Figure 11.h - Table down magnet 2

11.6 Gearbox cross shaft roll pin replacement

As a secondary overload protection device, the gearbox cross shaft is protected by roll pins which will shear, when overloaded.

If this occurs, they may be replaced as follows:

1. Remove the 6 x setscrews holding on the cover of the gearbox. Remove the cover and gasket.
2. Remove all broken parts of the roll pins
3. Ensure the hole in the table cross shaft and the hole in gearbox cross shaft line up correctly
4. Fit new roll pins (CFA00006 & CFA00009). Do not fit anything other than these!
5. Replace the gearbox cover ensuring the gasket is serviceable. If not, replace the gasket with a new part (CSE00006).
6. Replace the 6 x setscrews

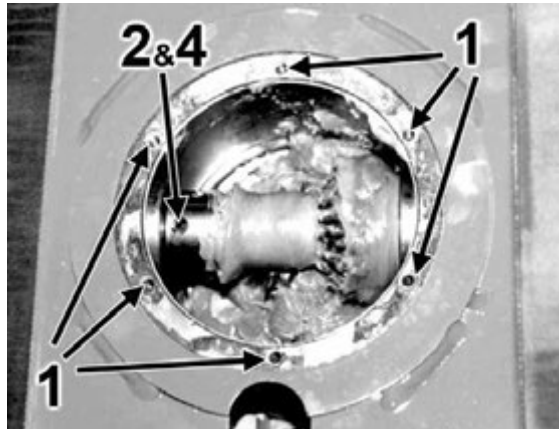

Figure 11.i - Gearbox cross shaft roll pin replacement

11.7 Cut & hold adjustment

The cut & hold may be adjusted both horizontally and vertically to allow for varying conditions and bales. Adjust as follows:

11.7.1 Horizontal adjustment

1. Loosen the 4 x M16 nyloc nuts holding on the "U" bolts. Do not remove them!
2. Slide the cut & hold to a new position. The plastic film should fall centrally into the cut & hold. Different bale lengths will affect this.
3. Tighten the 4 x nyloc nuts

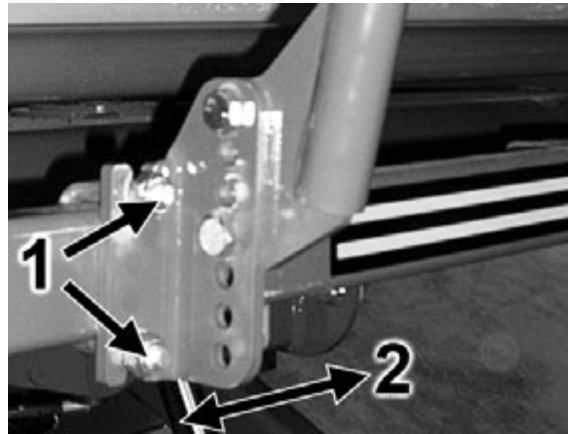

Figure 11.j - Horizontal adjustment

11.7.2 Vertical adjustment

1. Support the cut & hold
2. Remove the 4 x M16 bolts and nyloc nuts holding on the cut & hold
3. Move the cut & hold to a new position and secure the 4 x M16 bolts and nyloc nuts

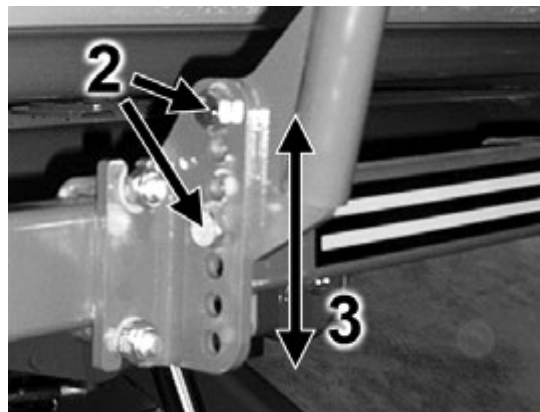

Figure 11.k - Vertical adjustment

11.8 Cut & hold accumulator pressure

The cut & hold is held open by a hydraulic accumulator which is primed before leaving the factory. If, for whatever reason, the pressure drops or increases it is possible to prime the circuit again, as follows.



WARNING: Care must be taken when carrying out this procedure

It is very important that care is taken in carrying out the following procedure to protect both the operator and any personnel that may be nearby! If you are unsure of how to carry out this procedure entrust the job to your **McHale** dealer.

11.8.1 To increase accumulator pressure

1. Remove the blanking cap on the hydraulic cylinder
2. Remove the cut & hold feed pipe (and adaptor) and fit it to the open port
3. Operate the cut and hold to prime the system. It only needs a small amount of oil to prime it back up.
4. Remove the hydraulic pipe (and adaptor) and refit it to its original position
5. Replace the blanking cap on the priming port. Operate the cut and hold to ensure it is opening and closing. Repeat if it is not fully primed.

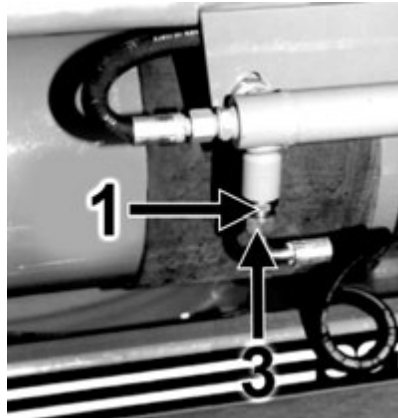

Figure 11.l - Increase accumulator pressure

11.8.2 To decrease accumulator pressure

1. Remove the blanking cap on the hydraulic cylinder
2. Insert a small punch into the hydraulic cylinder port. There is a one way ball valve in the cylinder which the punch needs to unseat to release oil. Always cover the punch with a cloth to prevent oil contacting skin.
3. Replace the blanking cap and test the cut and hold to ensure it is opening and closing correctly.

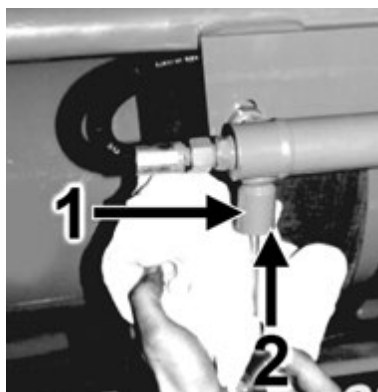

Figure 11.m - Decrease accumulator pressure

11.9 Chain adjustments

It is important for the efficient operation of the machine that all drive chains are kept correctly tensioned. The following is a general guide to chain adjustment.

McHale 995 L+T Square Bale Wrapper

The sag is measured at the midpoint of the chain between the sprockets. Always ensure one side of the chain is tight so that the correct reading is obtained. Even though some drives differ in detail the basic adjustments stay the same.

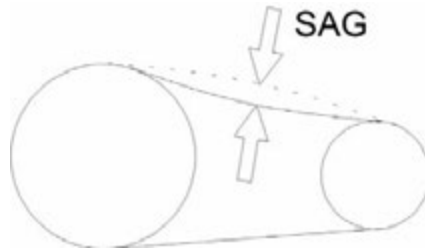

Figure 11.n - Chain adjustments

11.9.1 Table drive chain

After a period of time, it may become necessary to readjust the drive chain.

To adjust go through the following procedure:

1. Tip up the wrapper table and fit the safety bar securely
2. Stop the tractor/power unit and ensure that it cannot be restarted, while working on the machine.
3. Loosen the 4 x M16 bolts holding on the motor plate
4. Turn the M16 nyloc nut to adjust the chain. There should be 10-13 mm of sag in the chain.
5. Tighten the 4 x M16 bolts holding on the motor plate
6. Remove the table safety lock and lower the table down

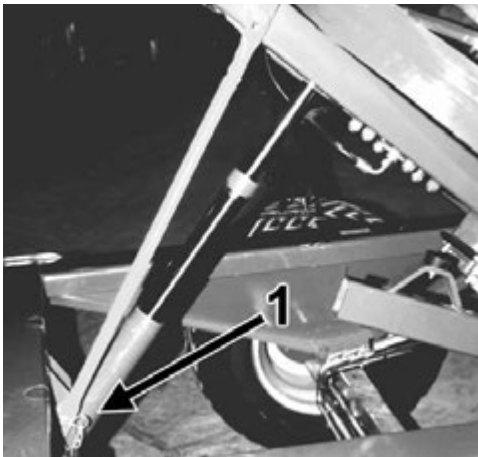

Figure 11.o - Tip up table & fit safety bar

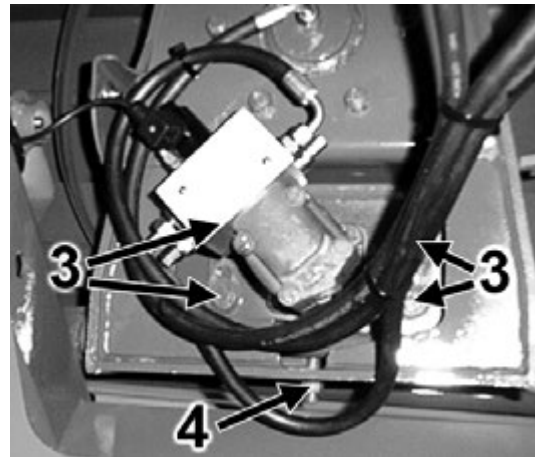

Figure 11.p - Table drive chain

11.9.2 Table cradle drive chains

After a period of time, it may become necessary to readjust the table cradle drive chains, either to tension the chains correctly or when the roller cradles centres are to be changed.

McHale 995 L+T Square Bale Wrapper

To adjust go through the following procedure:

1. Remove the chain guard by undoing the 2 x M8 setscrews
2. Loosen the 4 x M16 nuts and bolts holding on the bearings
3. Tighten the 4 x M16 nuts and bolts
4. Repeat for the other chain
5. Replace the chain guard with the 2 x M8 setscrews



NOTE: Ensure both chains have the same number of links

This procedure is also used for adjusting roller centres. The chain length may have to be adjusted to achieve this. Always ensure both chains have the same number of links.

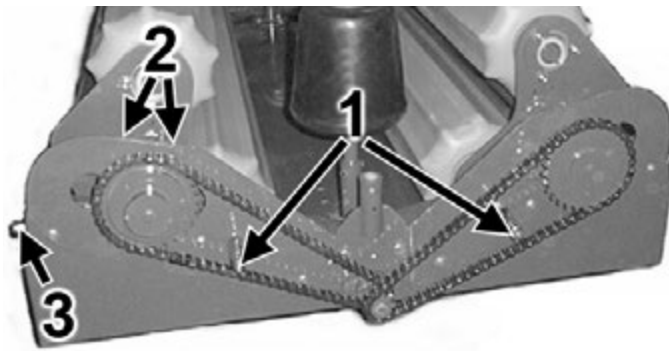

Figure 11.q - Table cradle drive chains

11.9.3 Table roller drive chains

After a period of time, it may become necessary to readjust the table roller drive chains.

To adjust go through the following procedure:

1. Remove the chain guard by undoing the 2 x M8 setscrews
2. Loosen the 3 x M10 nuts and bolts holding on the bearings
3. Adjust the roller using the snail cam
4. Repeat for the other roller drive chains
5. Replace the chain guard with the 2 x M8 handwheels

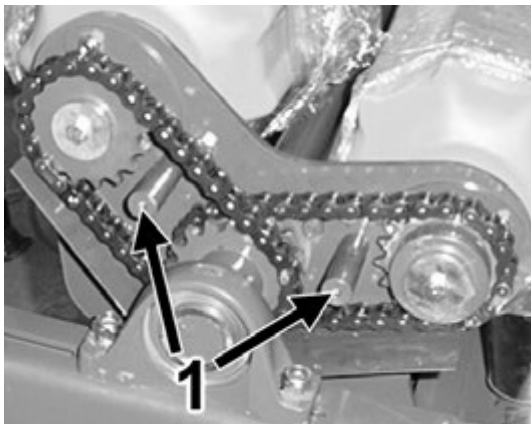

Figure 11.r - Table roller drive chains

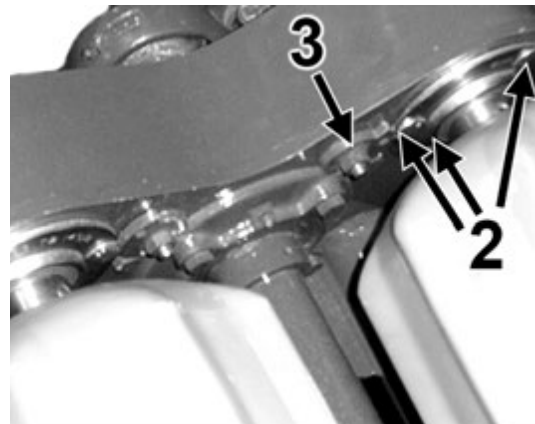

Figure 11.s - Table drive chain

12

Accessories & Optional Equipment

Certain accessories and optional equipment may or may not be available in all countries, depending on varying circumstances. The following key symbols help to explain what is sold as standard and what is optional equipment, or may not be available on the **McHale 995 L+T**. They are only correct at the time of print and may vary.

Key symbols	
Standard equipment	●
Optional equipment	⊙

12.1 Side Tip Damper ⊙

The side tip option is used for knocking the bale onto it's side and is very useful for coarse ground with strong stubble (which may have a tendency to puncture the film), as it allows the bale to land on it's edge, which has a much higher degree of film coverage. It is also very useful on hilly/sloping ground as it can prevent bales from rolling, when they land on their side.

12.2 Remote control kit for static machine operation (995 LSR & TSR) ⊙

The remote control kit is used for static wrapping. The kit includes a radio receiver and remote. See "Remote Type" on page 48 for more details.

12.3 Dispenser Gears

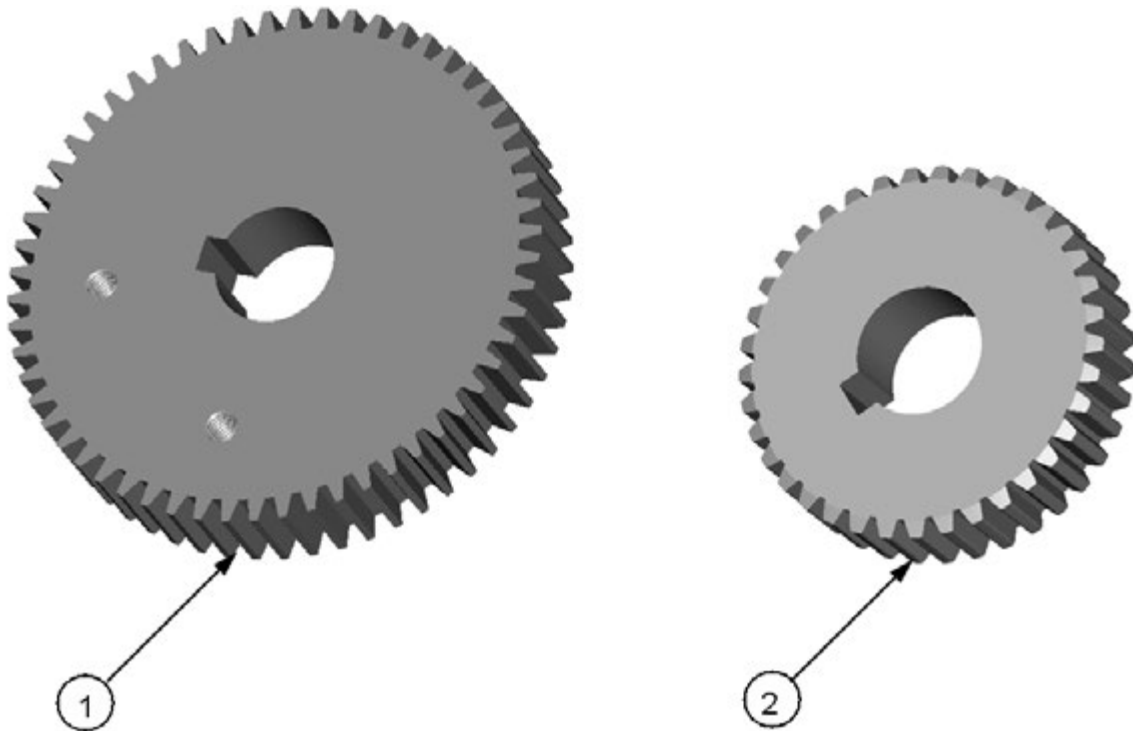

55% Gear option (● L Series & T Series)

Item	Part Code	Description	Qty
	ADP00019	Kit dispenser gears 55%	1
1	CMH00057	Gear spur 1.5 m 58t dispenser	1
2	CMH00174	Gear spur 1.5 m 37t dispenser	1

64% Gear option (⊙ L Series & T Series)

Item	Part Code	Description	Qty
	ADP00020	Kit dispenser gears 64%	1
1	CMH00056	Gear spur 1.5 m 59t dispenser	1
2	CMH00096	Gear spur 1.5 m 36t dispenser	1

13

Machine Maintenance

To maintain the **McHale 995 L+T** in good working order it is necessary to carry out preventative maintenance regularly. The following section gives details of how this may be carried out and how often it will be required.



ENVIRONMENT: Health and safety rules re. environmental damage

It is vitally important to observe health and safety rules in order to avoid unnecessary environmental damage or danger to anybody near the machine. This especially applies to the responsible disposal of oil. Never spill pollutants (oil, grease, filters, etc.) on the ground, never pour them down the drain and never discard them where they can pollute the environment. Always take waste materials to a recycling centre.

13.1 Maintenance intervals

The following intervals should be adhered to, in order to ensure a long and efficient life for the machine and maximum safety of personnel. They assume constant working during the wrapping season.

First 5 working hours

- Check all nuts and bolts for tightness and tighten, if necessary

Every day (See Figure 13.a)

- Grease sub chassis pivots (No. 1)
- Grease table tip hydraulic cylinder ends (No. 2)
- Check all guards and safety devices (No. 3)
- Check for any oil leaks and damaged pipes (No. 4)

Every week (See Figure 13.b)

- Grease table roller cradle bearings (No. 1)
- Grease cross shaft bearing (No. 2)
- Grease dispenser top coil roller shafts (No. 3)
- Grease cut and hold plunger (No. 4)

Every year (See Figure 13.c)

- Clean and lubricate dispenser gears (No. 1)
- Check table gearbox for grease (No. 2)
- Grease shearbolt to sprocket flanges on table drive cradles (No. 3)



CAUTION: Hydraulic hoses to be replaced every 5 years

All hydraulic hoses must be replaced every 5 years

It may become necessary from time to time to clean the dispenser rollers as they pick up the “tack” from plastic film. Clean off with kerosene.

At the end of the wrapping season the machine should be washed and cleaned. Any damaged paintwork should be touched up. Any maintenance or repairs should be carried out at this stage. The electronic control box is not waterproof, so it must be always be stored in a dry environment (See “Storage” on page 72). All exposed hydraulic cylinder rods should be greased.



WARNING: Wear proper safety gear & follow all instructions

Ensure to wear proper safety gear at all times when working with the machine, such as gloves, eye protection, etc. and follow all safety decals and instructions



WARNING: Inspections in the “Danger Zone” during machine operation require a second trained operator at the controls

McHale recommend that nobody is ever in the “Danger Zone” at any time during machine operation, but in the event of carrying out inspections (contrary to our safety recommendations!) when the machine is in operation, there must always be a second operator at the tractor controls (who is fully competent in the operation of both the tractor and machine), in case an emergency stop action is required.

McHale 995 L+T Square Bale Wrapper

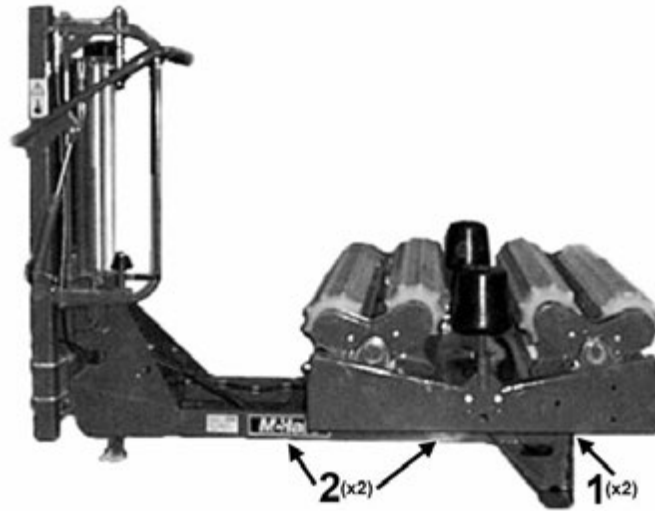

Figure 13.a - Daily greasing diagram for the 995 L+T

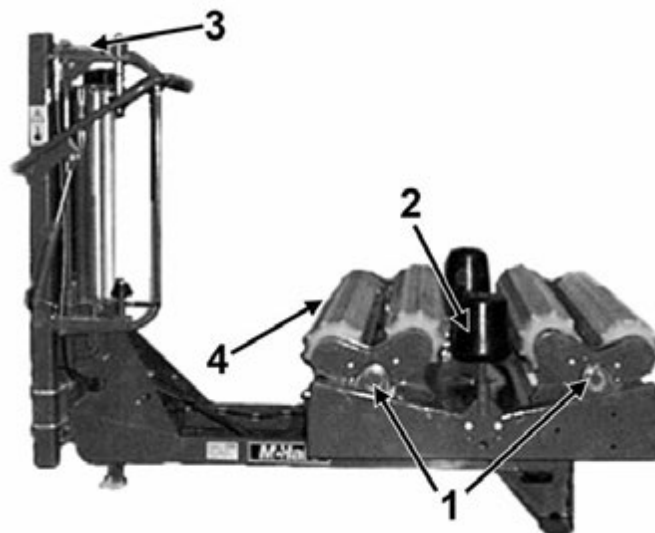

Figure 13.b - Weekly greasing diagram for the 995 L+T

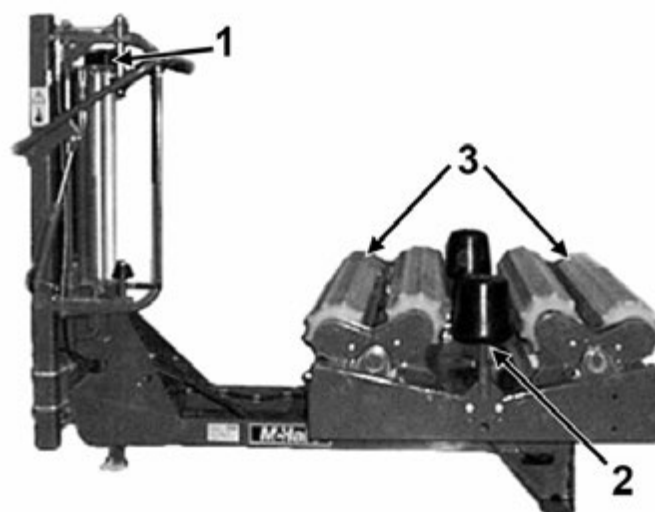

Figure 13.c - Yearly greasing diagram for the 995 L+T

13.2 Tightening torque values

It is important that the correct torques for fasteners are adhered to. Below are tables of recommended torques for these. These are to be used unless torques are otherwise specified. These values are for general use only. Check tightness of all fasteners periodically. (All torques are in Newton Metres - Nm.)

Nuts and bolts		Black, Phosphated or Galvanized		
Grade marking		8.8	10.9	12.9
	Dimensions	Metric standard thread		
Hex. bolts	M4	2.7	3.8	4.6
Din 931	M5	5.5	8	9.5
Din 933	M6	10	14	16
	M8	23	33	40
Socket head	M10	45	63	75
Cap screws	M12	78	110	130
Din 912	M14	122	175	210
	M16	195	270	325
Hex. nuts	M18	260	370	440
Din 934	M20	370	525	630
	M22	510	720	870
	M24	640	900	1080
	M27	980	1400	1650
	M30	1260	1800	2160
	Dimensions	Metric fine thread		
Hex. bolts	M8 x 1	25	35	42
Din 960	M10 x 1.25	48	67	80
Din 961	M12 x 1.25	88	125	150
	M12 x 1.5	82	113	140
Hex. nuts	M14 x 1.5	135	190	225
Din 934	M16 x 1.5	210	290	345
	M18 x 1.5	300	415	505
	M20 x 1.5	415	585	700
	M22 x 1.5	560	785	945
	M24 x 2	720	1000	1200
	M27 x 2	1050	1500	1800
	M30 x 2	1450	2050	2500
NOTE:	For cadmium or copper plated bolts and nuts a torque value must be used that is lower than the value stated above			

14

Storage

14.1 End of season

- Carefully clean the wrapper sections inside and out. Dirt and foreign objects are likely to draw moisture and cause rusting of steel components. In the case of using a high pressure washer, do not point pressurized water at or near electrical components, pivots points, valves or bearings. **McHale** recommend that the machine be blown down with an air line as opposed to a pressure washer in order to protect the overall paint work on the machine.
- On electronic control machines, remove the control box from the tractor and store in a dry, safe environment
- Lubricate all pivot points and apply a thin layer of grease to all adjustment bolt threads and exposed ram rods
- Any components from which paint has become worn should be touched up or coated with grease to prevent rusting
- Remove all dirt from all chains and blow dry using compressed air

14.2 Start of season

- Fully review this operators instruction manual
- Lubricate all pivot points
- Tighten all bolts, nuts and setscrews (Refer to “Tightening torque values” on page 71)
- Check air pressure of all tyres (995 T)
- On electronic control machines, connect the control box and inspect it for the correct operation of all functions (See “Electronic Control Box Functions” on page 41)
- Inspect and modify, if necessary, all machine adjustments (See “Field Operation & Wrapper Adjustments” on page 57)
- Check film wrapping adjustments and replace cut and hold knife. Ensure to wear protective clothing whenever working in this area!
- Inspect aluminium dispenser rollers for a build up of tack/glue, clean off using kerosene or diesel oil and wipe rollers dry.

15

Trouble Shooting

15.1 Trouble shooting overview

This section has been compiled by **McHale** Service Personnel in conjunction with **McHale** Importers and Dealers.

It outlines some common problems which can occur and acts as a quick reference section or check list to resolve the problem. It is important to note that it outlines the common problems and to this effect it is not exhaustive.

Should you experience additional problems which you need help with; please do not hesitate to contact your **McHale** Dealer.

15.1.1 Table

Symptom	Reason	Solution
Table rotates but bale not indexing	Table drive roller shearbolt broken	Replace shearbolt
	Gearbox cross shaft roll pins broken	Replace roll pins
Table stopping in the wrong position (Electronic machines)	Magnet settings	Reset magnets
	Not starting in the correct position	Start with cut & hold at the rear of the machine
	Slow down setting in the control box	Adjust
	Slow speed valve not working	Check electrical connections
	Dirt in slow speed cartridge	Clean cartridge
	Slow speed set too fast	Set table rotation to 10 RPM
Table moving in tip position	Drive chain loose	Tighten chain
Table slow to tip down	Back pressure too high	Ensure free flow return is fitted
	Faulty quick release couplings	Replace couplings

McHale 995 L+T Square Bale Wrapper

Symptom	Reason	Solution
Machine tips bale but does not reset to load	Tip sensor faulty	Locate and replace
	Magnet broken	Locate and replace

15.1.2 Plastic film

Symptom	Reason	Solution
Plastic not stretching	Building up of tack/glue on dispenser rollers	Clean off with kerosene
	Torsion spring weak on dispenser	Replace spring
Plastic getting caught around the cut & hold (Electronic machines)	Table down magnet set too high	Reset table down magnet

15.1.3 Cut & hold

Symptom	Reason	Solution
Cut & hold not catching plastic film	Positioned incorrectly	Check position
	Table not stopping in the correct tip off position	Check and adjust magnets if necessary
Cut & hold not opening	Pressure low on accumulator	Prime accumulator
Cut & hold not closing	Pressure high on accumulator	Release pressure from accumulator
Cut & hold leaks back slowly	Seals weak in the gearbox	Replace seals
	Loose hydraulic fitting on gearbox	Tighten hydraulic fitting
Cut & hold and tip-up cycles very slow	Tractor pressure too low	Ensure tractor has 150 bar pressure
	Faulty pressure switch (electronic machines)	Replace pressure switch
	Relief valve set too low	Set to 150 bar pressure

15.1.4 Control box

Symptom	Reason	Solution
Control box not counting	Sensor damaged	Locate and replace
	Magnet broken	Locate and replace
	Sensor - magnet clearance	Adjust sensor approx. 10-15 mm from magnet.
	Faulty control box	Replace control box
“LOW BATT” appears on the control box	Supply voltage too low	Check battery and charging system
Only half the number of actual rotations is displayed on the control box	One set of magnets missing	Replace the missing set of magnets
Control box will not switch to “auto” setting	Loom not connected to the box	Connect loom

15.1.5 Hydraulics

Symptom	Reason	Solution
Hydraulics under pressure when the wrapper is idle	Valve set to closed centre on open centre system	Change the setting
Hydraulic system vibrating	Incorrect valve setting for the tractor is being used	Set the valve to suit the tractor hydraulic system being used

15.1.6 Remote control

Symptom	Reason	Solution
Remote control receiver not accepting a signal	Not connected properly	Check on the rear of the control box
	Batteries exhausted on a handpiece	Replace the batteries
	Not pressing the Start button for long enough	Press the button for 2 to 3 seconds
	Sunlight shining direct into the receiver (infrared type receivers only)	Turn away or shade
	Operating through tinted glass (infrared type receivers only)	Operate where glass cannot come in the way

15.1.7 Control valve

Symptom	Reason	Solution
Dump valve on control valve leaking (electronic machines)	Back pressure too high	Ensure free flow return is fitted
	Return hose not connected	Connect hose

16

Certification & Warranty

16.1 Declaration of Conformity

The Declaration of Conformity is provided by **McHale**. It certifies the new machine under all the relevant provisions of the EC Machinery Directive and the National Laws and Regulations adopting this directive.

The declaration gives a description of the machine and its function, along with the model and serial number details. See Declaration of Conformity on the next page.

By any alteration of the machine, the Declaration of Conformity, as well as the CE sign on the machine, loses its validity.

16.2 PDI Form

The PDI (Pre-Delivery Inspection) form is filled out on the commissioning of every new machine, by the **McHale** Dealer. The following checks are completed and signed off:

- All parts and accessories are provided to the customer, with the machine
- Machine is reassembled correctly
- Tyre pressure is correct (995 T)
- Hydraulics, electrics and lighting (995 T) are working
- New owner has been instructed on how to operate & maintain the machine

The PDI is included in the Operator Manual, please see page 79.

16.3 Change of ownership pre-checks

The PDI (Pre-Delivery Inspection) form that is filled out on the commissioning of every new machine, should also be used during the transfer of ownership of a **McHale** machine. The same check list must be completed and any areas requiring attention addressed before the re-sale of the machine should occur. Pay particular attention to all safety related areas. Take time to familiarise the new owner with machine operation, maintenance and all its safety features.

16.4 Limited Warranty

Limited Warranty conditions are supplied with each **McHale** product. They cover the terms & conditions associated with abnormal failure under normal working conditions. Please see page 80 for more detail.

Declaration of Conformity



EC MACHINERY DIRECTIVE: 2006/42/EC DECLARATION OF CONFORMITY

We hereby certify that the machinery stipulated below complies with all the relevant provisions of the EC Machinery Directive and the National Laws and Regulations adopting this Directive. Modifications to the machine, without prior approval from the undersigned, will render this declaration null and void.

Machine description and function: Square Bale Wrapper for wrapping bales of agricultural fodder with agricultural bale film wrap.

Model: **995 L+T** Serial Number: _____

Name of Manufacturer: **McHale Engineering**
Address: Ballinrobe, Co. Mayo. Rep. of Ireland

Is in conformity with the provisions of the following other EC directives:
2004/108/CE - EMC for the control unit

Technical file compiled by: James Heaney
c/o **McHale Engineering**
Ballinrobe, Co. Mayo. Rep. of Ireland

Harmonized standards applied:
EN ISO 12100: Safety of machinery - Basic concepts, general principles for design
Part 1: Basic terminology, methodology
Part 2: Technical principles and specifications
EN ISO 4254 Part 1: Agricultural Machinery - Safety and general requirements

Signed: 
Date: **Place:** Ballinrobe, Co. Mayo, Rep. of Ireland
Name: James Heaney
Position: Design Office Manager

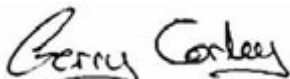
Signed: 
Date: **Place:** Ballinrobe, Co. Mayo, Rep. of Ireland
Name: Gerry Corley
Position: Quality Manager

Pre-Delivery Inspection Form

	
<p>PRE-DELIVERY INSPECTION (PDI) 995 L+T Square Bale Wrapper</p>	<p>Castlebar Road, Ballinrobe, Co. Mayo Tel: +353 (94) 95 20300 Fax: +353 (94) 95 20356 E-mail: sales@mchale.net Web: www.mchale.net</p>
<p>DEALER:.....</p> <p>Full Address:.....</p> <p>.....</p> <p>Fitter:.....</p>	<p>Model: 995 L+T Square Bale Wrapper</p> <p>Serial No:.....</p> <p>Date Delivered:.....</p> <p>Date Inspected:.....</p>
<p>CUSTOMER:.....</p> <p>Full Address:.....</p> <p>.....</p> <p>.....</p>	<p>Tel:.....</p> <p>Mobile:.....</p> <p>E-mail:.....</p>
<p>ENSURE THAT THE TRACTOR IS OF THE CORRECT SPECIFICATION FOR THIS MACHINE REFER TO THE OPERATOR INSTRUCTOR MANUAL BEFORE MAKING ANY ADJUSTMENTS!</p>	
<p>1. Check that all accessories are with the Owner/Operator. Check Operator Instruction Manual and Parts List.</p>	<p>10. Where the remote control option is supplied with the machine, ensure that it is fitted correctly.</p>
<p>2. Ensure machine is re-assembled correctly. (Refer to all assembly instructions supplied).</p>	<p>11. Check all manual functions on the control unit. Run machine through an automatic cycle.</p>
<p>3. Ensure that the wheels are correctly fitted (i.e. valve to the outside). Torque wheel nuts correctly (995 T).</p>	<p>12. Check for smooth operation of the lift-arm, table, rollers and all moving parts.</p>
<p>4. Check for correct tyre-type, tread and pressure (995 T).</p>	<p>13. Check that all electrics and lights function correctly.</p>
<p>5. Ensure drawbar is fitted correctly before coupling machine to tractor. Torque all bolts (995 T).</p>	<p>14. Check dispenser(s) are running smoothly & free from damage or grit.</p>
<p>6. When hitched to tractor check that the machine is level with the ground. Adjust drawbar if necessary. Attach 7 pin plug for lighting system (995 T).</p>	<p>15. The operator must be fully aware of all hazards, controls (electric & hydraulic), all functions & safety devices of both the machine and the tractor.</p>
<p>7. Connect hydraulic hosing to tractor and ensure proper hydraulic setup. Note: Ensure free flow return to tank.</p>	<p>16. Ensure that the owner/operator reads the Operator Instruction Manual and understands fully all safety and operating aspects of the machine as described therein.</p>
<p>8. On electronic machines, ensure control-unit power supply is 12v direct from battery otherwise the machine may malfunction.</p>	<p>17. Instruct operator on machine maintenance, i.e. Check chain tensions, adjustments, tyre pressure and wheel nuts, also areas to be greased daily along with other routine functions.</p>
<p>9. On electronic machines, ensure that the control-unit is on the correct program to suit the machine specification and that it is starting & finishing in the correct position.</p>	
<p>I am satisfied that the above checks have been carried out, and that the machine is complete with all accessories and manuals.</p>	
<p>Signed:.....</p>	<p style="text-align: center;">(Dealer)</p> <p>Date:.....</p>
<p>Signed:.....</p>	<p style="text-align: center;">(Owner)</p> <p>Date:.....</p>
<p>This machine must be registered on www.mchale.net by the Dealer in order to qualify for Warranty!</p>	

A signed copy of this form is to be retained by both the Dealer and the Customer.

McHale Limited warranty

McHale Engineering, Ballinrobe, Co. Mayo, Ireland (hereinafter called “the company”) warrants to the original retail purchaser that new products sold and registered with the company, shall be, at the time of delivery, free from defects in material and workmanship, and that such equipment is covered under Limited Warranty providing the machine is used and serviced in accordance with the recommendations in the Operator’s manual.

This Limited Warranty covers the equipment for 10,000 bales, or a period of one year starting from the date the equipment is commissioned, whichever comes first.

The online submission of the pre-delivery inspection (PDI) form by the dealer (Importer) is taken as evidence of the delivery of the machine to the original retail purchaser. This is compulsory, and is required to record the machine in the **McHale** warranty system.

These conditions are subject to the following exceptions:

- Parts of the machine which are not of **McHale** manufacture, such as tyres, PTO shafts, slip clutches, hydraulic cylinders, etc. are not covered by this limited warranty, but are subject to the warranty of the original manufacturer. Warranty claims applying to these types of parts must be submitted in the same way as if they were parts manufactured by **McHale**. However, compensation will be paid in accordance with the warranty agreement of the manufacturer concerned.
- This limited warranty does not apply to failure through normal wear and tear, to damage resulting from negligence or from lack of inspection, from misuse, from lack of maintenance and/or if the machine has been involved in an accident, lent out or used for purposes other than those for which it was intended by the company.
- This Limited Warranty will not apply to any product that has been altered or modified in any way without the express permission of the company, or if parts not approved by **McHale** are used in repair.
- The company take no responsibility for any additional costs, including loss of oil and/or consumables incurred during the failure and repair of a product
- The company cannot be held responsible for any claims or injuries to the owner or to the third party, nor to any resulting responsibility.
- Also, on no account can the company be held liable for incidental or consequential damages (including loss of anticipated profits) or for any impairment due to failure, a latent defect or a breakdown of a machine.

The customer will be responsible for the following costs:

- Normal maintenance such as greasing, maintenance of oil levels, minor adjustments, etc. as specified in the Operator’s manual.
- Labour charges other than originally agreed, incurred in the removal and replacement of components.
- Dealer’s travel time and travel costs to and from the machine.
- Parts defined as normal wear items such as, but not limited to PTO shafts, chains, tyres, bearings, belts, blades, knives, tines, tine bars, slip clutches, nylon chain runners and slides, etc. that are not covered under the Limited Warranty.

McHale 995 L+T Square Bale Wrapper

The importer will be responsible for the following costs:

- All warranty labour charges.

The warranty is dependent on the strict observance of the following:

- The machine has been put in service by the **McHale** dealer according to our instructions.
- The online pre-delivery inspection (PDI) form has been correctly completed by the dealer.
- A printed version of the PDI form has been signed and dated by the original retail purchaser. This copy is to be stored by the dealer and made available to **McHale** when requested.
- The warranty claim is submitted using the **McHale** online claims system.
- The warranty claim must be submitted by the original retailing **McHale** dealer only.
- The decision of the Company in all cases is final.
- Damaged parts should be held by the dealer until credit has been given, or a returns request has been issued.
- Parts must be returned to **McHale**, with the **McHale** claim number written clearly on each individual part. These parts must be free from dirt and oil. If a part is returned in an unfit state, the claim will be refused.
- If damaged parts have been returned to the company and warranty is refused, the dealer is allowed a period of one month from the date of receiving our notification to request the return of the damaged parts to the dealer site.

Further conditions - limits of application and responsibility:

- This Limited Warranty cannot be assigned or transferred to anyone without the prior written consent of the Company.
- **McHale** Dealers have no right or authority to assume any obligation or take any decision on the Company's behalf, whether expressly or tacitly.
- Technical assistance given by the company or its agents for repairing or operating equipment does not lead to any responsibility on the Company's behalf and cannot under any circumstances bring novation or derogation to the conditions of the present Limited Warranty.
- The Company reserves the right to incorporate changes in its machines without prior notice and without obligation to apply these changes to machines previously manufactured.
- The present Limited Warranty excludes any other responsibility, whether legal or conventional, express or implied, and there are no warranties extending beyond those defined herein.